

Media: air – water – gas – light oil - vacuum
 Pressure range: 0 to 15 bar max
 Media temperature: 100° C max
 Ambient temperature: -10° to +50° C max
 Media viscosity: 40 centistokes max
 Mounting: any position
 Weight (including coil): 280 g
 Opening or Closing Time: 20 mSec Max

3/2 Brass

(1/8 Exhaust)
 N/C, N/O & UNIVERSAL
 3 WAY DIRECT ACTING

TYPE 300201

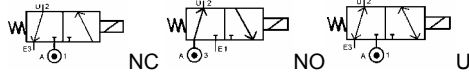

PRESSURE

TYPE	Ø Port	Flow Rate Ø Orifice (mm)	Kv Ltr/min	Pressure Rating (bar)			Part Number	List Price	
				Min ΔP	AC 10 watt Coil	DC 10 watt Coil			DC 18 watt Coil
3/2 NC	1/8 BSP	1.5	1.2	0	15	15	-	315201 + seal + 0181 + voltage + coil size	£46.81
		2	1.7	0	13	13	-	320201 + seal + 0181 + voltage + coil size	
		2.5	2.2	0	10	10	-	325201 + seal + 0181 + voltage + coil size	
	1/4 BSP	1.5	1.2	0	15	15	-	315201 + seal + 0141 + voltage + coil size	
		2	1.7	0	13	13	-	320201 + seal + 0141 + voltage + coil size	
		2.5	2.2	0	10	10	-	325201 + seal + 0141 + voltage + coil size	
3/2 NO	1/4 BSP	1.5	1.2	0	15	15	-	315201 + seal + 0140 + voltage + coil size	
		2.5	2.2	0	9	9	-	325201 + seal + 0140 + voltage + coil size	
		3	2.8	0	6.5	6.5	-	330201 + seal + 0140 + voltage + coil size	
3/2 U	1/4 BSP	1.5	1.2	0	9	-	10	315201 + seal + 0142 + voltage + coil size	£52.59
		2.5	2.2	0	6	-	6	325201 + seal + 0142 + voltage + coil size	
		3	2.8	0	2	-	3	330201 + seal + 0142 + voltage + coil size	

OPTIONS

Connector PG9 – DIN 43650 A Explosion Proof Enclosure ATEX II 2 G/D EexdIICT6, IP65 85°C (Ambient T° from -20°C to +40°C)  NBR, EPDM or FKM seals Manual Over ride NPT Thread	Included +£199.33 Included +£7.20 +£22.55
--	--

ELECTRICAL DATA

Voltage (-10% + 15%) Continuous duty 100%	Coil Size	Power		Insulation class	Enclosure	Electrical connections
		Inrush	Holding			
~ 24 - 48 - 110 - 230 - 380 (50/ 60Hz)	30	26 VA	14 VA	F 155°C	IP 65 with connector	3 spades DIN 43650A DIN 40050 VDE 0110
= 12 - 24 - 48 - 80 - 190 (DC)	30	10 Watts				
	36	14 - 20 Watts				

CONSTRUCTION

Body: Brass
 Tube and internal parts: Stainless steel
 Seals and gaskets: NBR or EPDM or FKM
 Moulded coil: Resin

REPAIR KIT

Coil	Coil size (30 or 36) + voltage
Complete plunger + O rings	KIT + valve part number

OVERALL DIMENSIONS

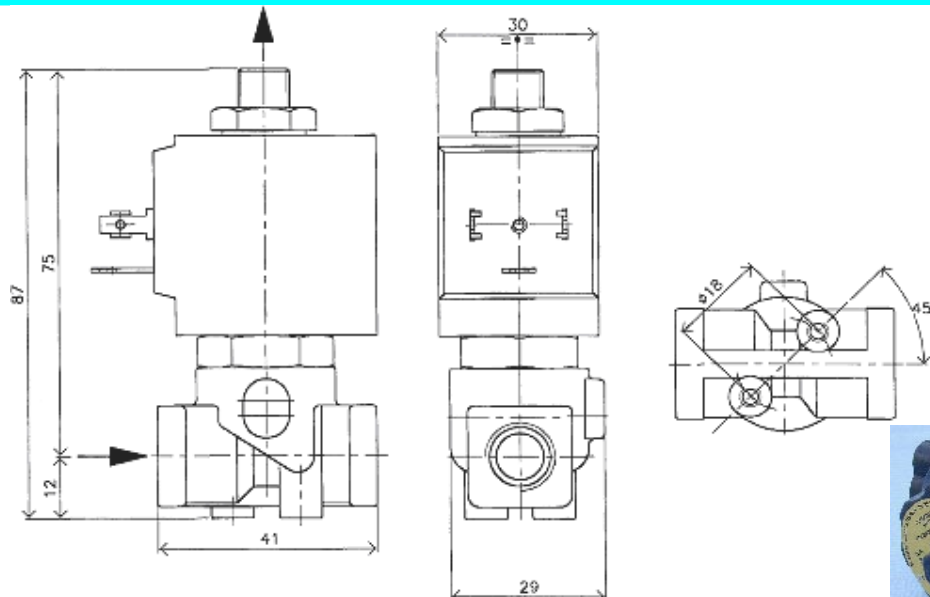

Atex
 Coil
 Page
 144