

# Flow-Converter UNICON®-DF

## Flow measurement with pulse sensors

### Features

- Measuring range programmable  
from -99999 ... 99999 Digit
- Measuring unit programmable  
e.g. l/s; l/min; l/h; m<sup>3</sup>/s....;  
(US)gal/s....; (US)bar(rel)/s....
- Totalizers programmable
- Additional 2. measuring input
- Output 4 ... 20mA, loop powered
- Pulse-output for external evaluation
- LCD-Text Display
- 2 electronic alarm outputs, voltage free
- Simulation mode for flow (manual operation)
- Protection IP65



Fieldcase  
100x100x60 mm (BxHxT)

### General

The Flow-Converter UNICON-DF is used in food technology, chemical and pharmaceutical industry and water technology. In connection with any type of pulse flow sensor the flow rate can be measured, displayed and converted in a 4 ... 20 mA signal. An additional feature is the summation function (totalizer). Using the alarm outputs a quantity dosage can be realized.

### Short information

|                   |  |
|-------------------|--|
| Programming       | The front panel keypad can be used to program all designated functions.  |
| Measurement value | The measured values are averaged continuously over a period of 0.1 ... 10 s (programmable). This period limits the minimum input frequency, because at least two impulses must arrive within.  |
| Totalizers        | 2 counters (totalizers) are available. The daily totalizer can be reset manually. Automatic reset takes place by cutting off power. The overall totalizer is zero voltage protected and can only be reset by a special code (password protection). |
| Pulse output      | Allows an external summation of flow quantity.   |
| Alarm outputs     | Switching performance of the alarm outputs is programmable as minimum or maximum function. The state of the alarm outputs is shown in the LCD-Display  |

---

---

## Technical data

### Power supply

|                     |  |
|---------------------|--|
| Supply voltage      | : 12 ... 30 V DC, loop powered<br>Using Namur sensors or sensors with NPN- and PNP output with power demand > 5 V/ > 2 mA a separate supply is necessary (12 ... 30 V DC). |
| Working temperature | : -10 ... 55 °C  |
| Isolation           | : between analog output/alarm output 1/alarm output 2/impulse output/external sensor supply  |
| Rated voltage       | : 500 V DC, between analog output/alarm output 1/alarm output 2/impulse output/external sensor supply  |
| CE - conformity     | : EN50022, IEC61000-4-3/4/5  |

### Measuring input

|                  |   |
|------------------|---|
| Typ              | : Inductive transmitter (coil), Namur-sensor or e.g. Hall-Sensor (rectangular pulse) programmable. Alternatively extern pulses 0/5 ... 24 V DC. |
| Input coil       | : switching threshold programmable from $\pm 5$ ... $\pm 1000$ mV   |
| Input NPN-Sensor | : low level < 0.9 V , high level > 2.1 V pull-up-resistor 20 k $\Omega$   |
| Input PNP-Sensor | : low level < 0.9 V , high level > 2.1 V pull-down-resistor 20 k $\Omega$   |
| Input Namur      | : low level < 1.4 mA , high level > 1.8 mA , hysteresis ca. 0.4 mA  |
| Input frequency  | : 0.1/10 ... 2000 Hz (depends on the programmed measuring interval)   |

### Flow output

|                         |   |
|-------------------------|---|
| Current output          | : 4 ... 20 mA, external load RA [ $\Omega$ ] $\leq \frac{\text{Supply voltage} - 12 \text{ V}}{0,02 \text{ A}}$ |
| Accuracy                | : < 0.1 % of the measuring value  |
| Temperature coefficient | : < 0.01 %/ °C  |

|              |  |
|--------------|--|
| Pulse output | : 12 ... 30 V DC, load max. 60 mA, short circuit protected                   |
| Pulse width  | : 100 ms   |
| Frequency    | : max. 5 Hz<br>Quantity/Volume per pulse programmable from 1 ... 99999 digit |

### Alarm outputs

|              |  |
|--------------|--|
| Transistor   | : 12 ... 30 V DC, load max. 60 mA, short circuit protected |
| Voltage drop | : < 2 V (at max. load)                                     |

### Display

|           |  |
|-----------|--|
| Flow      | : -99999 ... 0 ... 99999 digit, max 3 decimal points   |
| - Unit    | : l/s, l/min, l/h; m <sup>3</sup> /s, m <sup>3</sup> /min, m <sup>3</sup> /h; (US)gal/s, (US)gal/min,(US)gal/h; bar(rel)/s, bar(rel)/min, bar(rel)/h |
| Totalizer | : -9999999 ... 0 ... 9999999 digit, max. 3 decimal points  |
| - Unit    | : l, m <sup>3</sup> , (US)gallon, barrel   |
| - Storage | : Daily totalizer not voltage safe<br>Overall totalizer voltage safe   |

### Case

|                       |   |
|-----------------------|---|
| Material              | : Field-case<br>case polyamide with fibre-glass PA6-GF/GK 15/15<br>front foil polyester |
| Dimensions            | : 100 x 100 x 60 mm (WxHxD)   |
| Weight                | : max. 360 g  |
| Electrical connection | : Screw terminal pressure plate, 2.5 mm <sup>2</sup> flexible, 4 mm <sup>2</sup> wire   |
| Protection            | : IP65, terminals IP20 finger safe acc to German BGV A3                                 |

**Legend (open lid)**

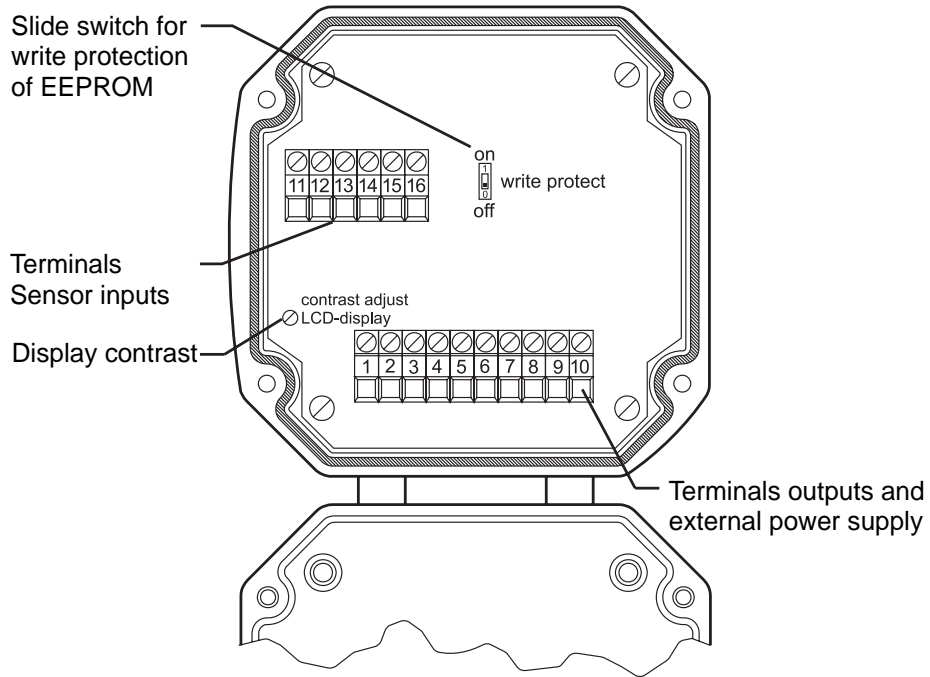

**Dimensions**

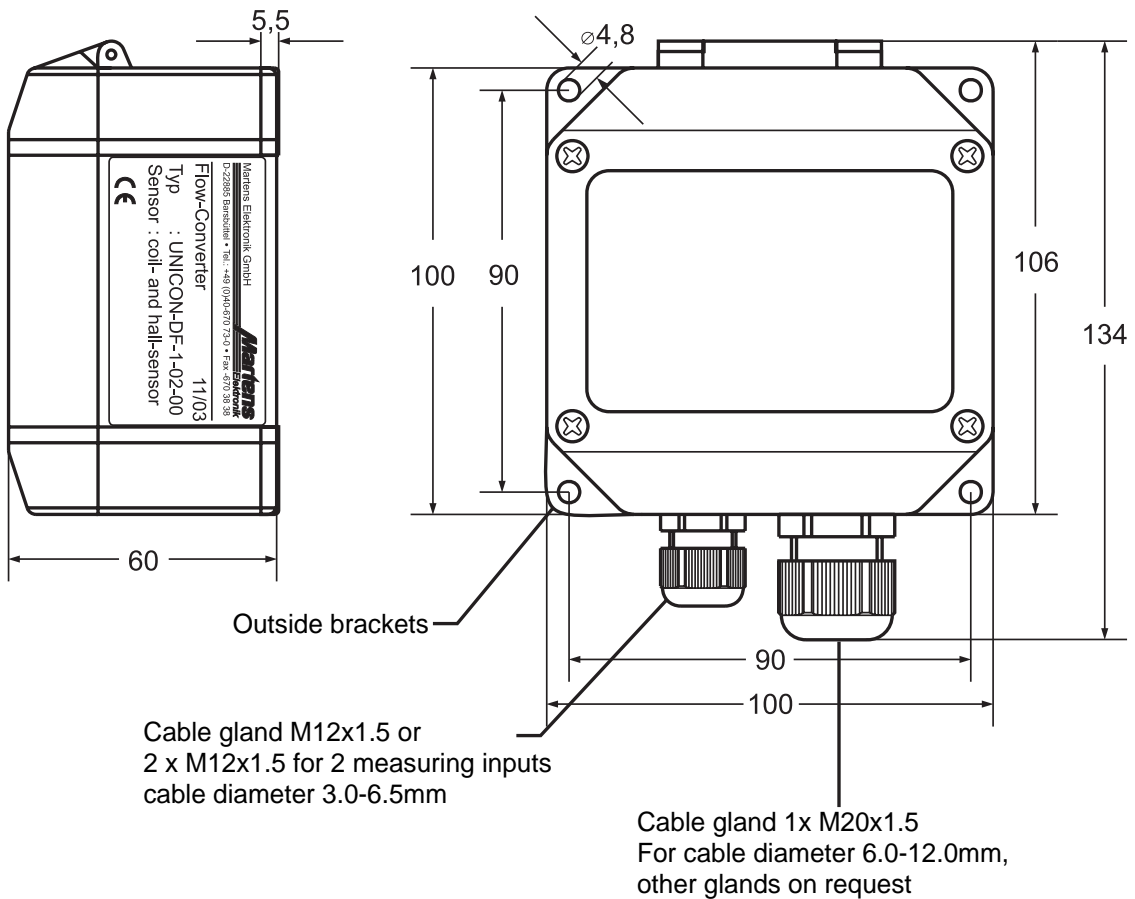

## Connection diagram

### Terminals output

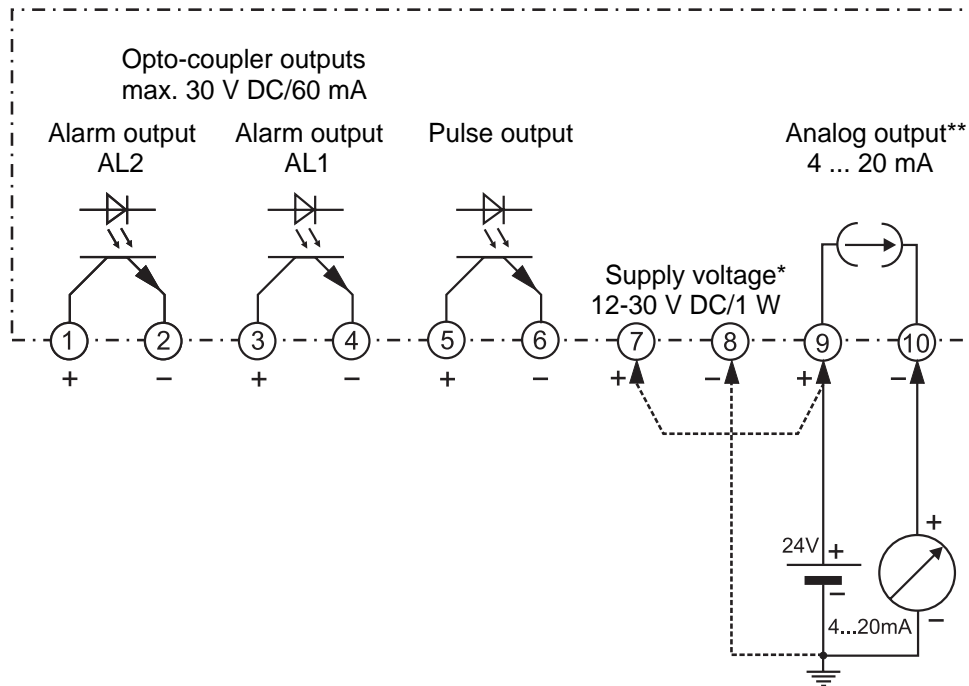

\* For supplying the converter use terminals (9) and (10) as shown. If the converter is used for monitoring only, terminals (9) and (10) must be connected direct to the supply voltage.

\*\* Separate supply voltage over the terminals 7 and 8 only when using Namur sensors (according to DIN EN60947) or sensors with NPN- or PNP output with power demand  $U_b > 5 \text{ V} / > 2 \text{ mA}$ .

### Terminals sensor inputs

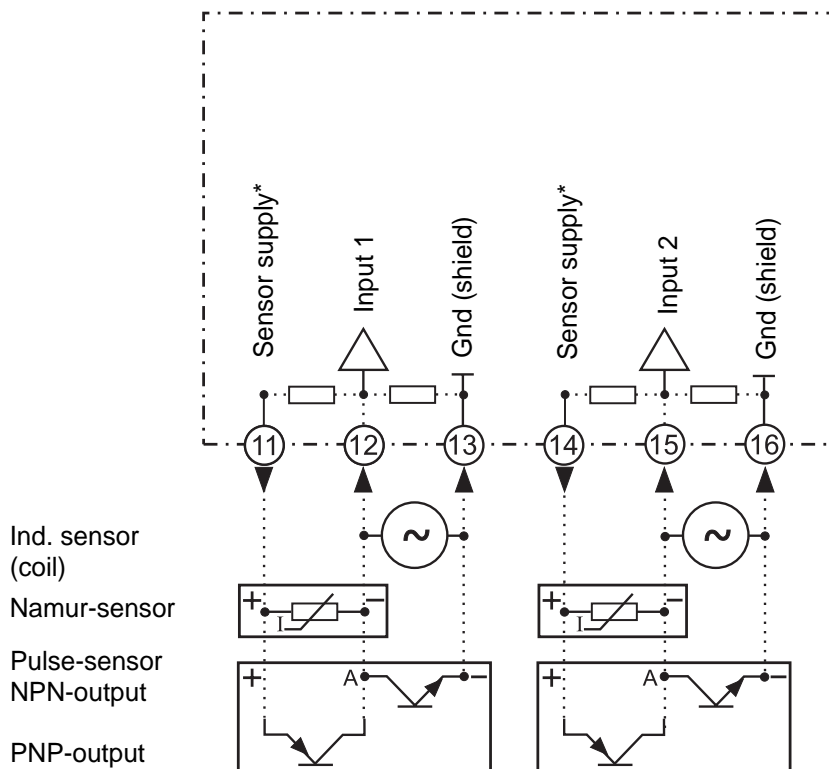

## Panel controls and indicators

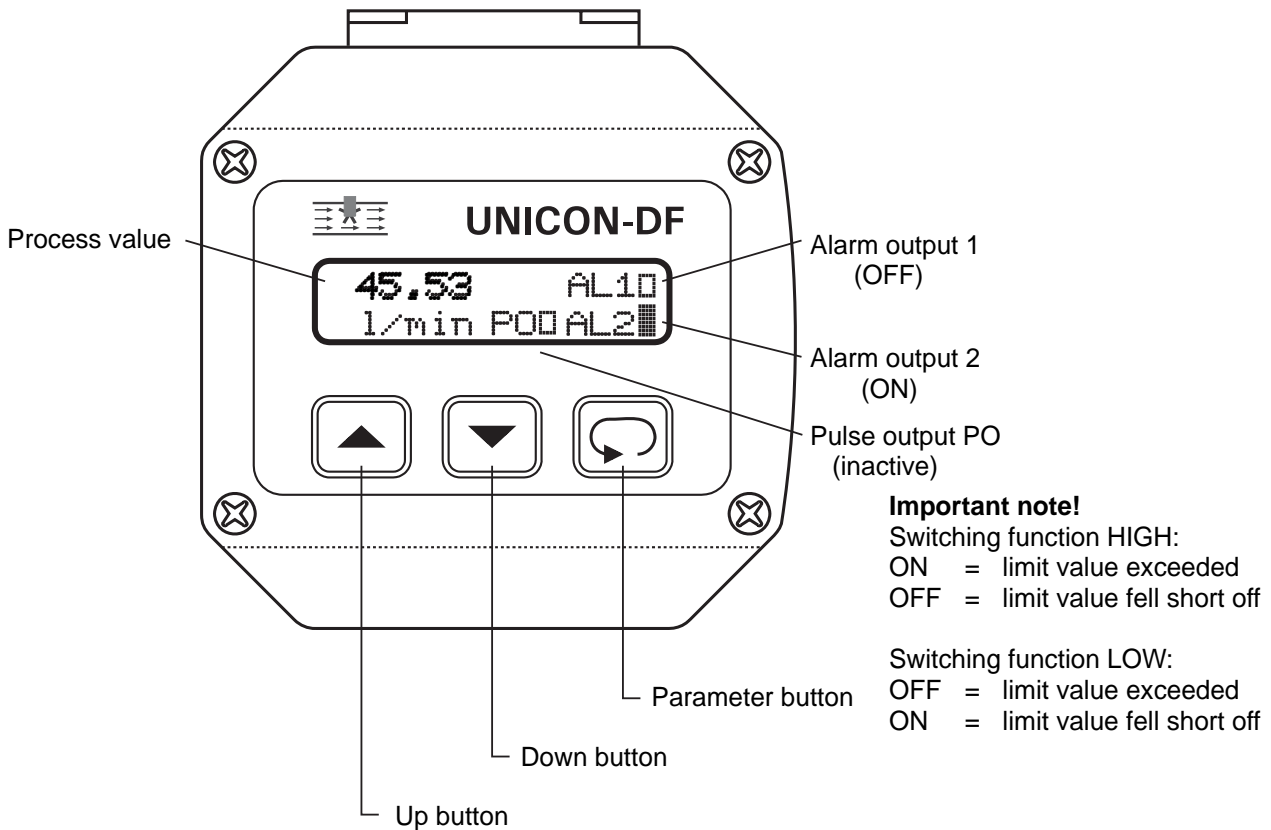

## Instructions

Operating of the device is arranged in 2 levels. The desired parameter can be called by button . For selection within a parameter use buttons and .

Button combinations (press buttons at the same time):

- + 1 Parameter back
- + Parameter to "0" or minimum value

When the power supply is switched on, the UNICON initializes itself. The display shows the device type UNICON-CL and software version. After initializing the current measurement values are displayed.

The **configuration level** is called-up by pressing the button . Now all the parameters defining the function of the UNICON can be programmed. After pressing the button again, the entered data will be stored.

When the configuration is finished, or when no button is pressed for more than 120 seconds, the program jumps back to the working level. Leaving the **configuration level** is possible at any time when pushing the button for 2 seconds.

Error code:

Display is flashing                      the measured signal exceeds the programmed range



After installation, the device must be configured for the intended use. See page 6.

## Programming

Notes to representation



Parameter is only displayed if configured



Parameter is only displayed if included (see order code)

**Note!** During the configuration only those parameters will be displayed, which are not excluded by other parameter settings.

## Working level

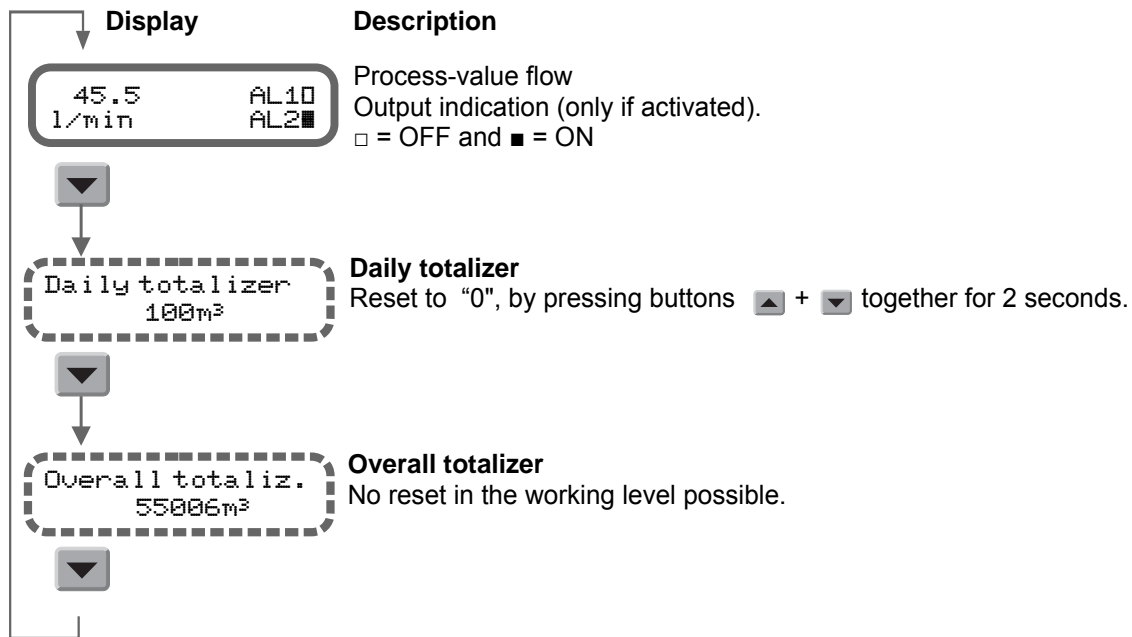

## Configuration level

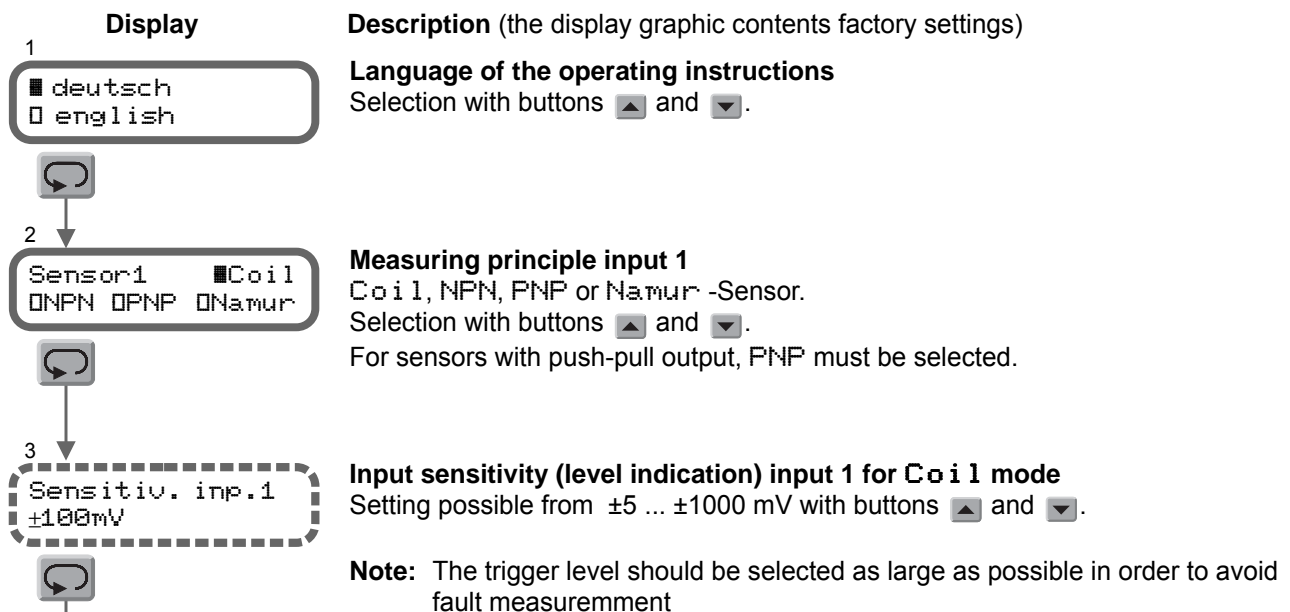

continue page 7

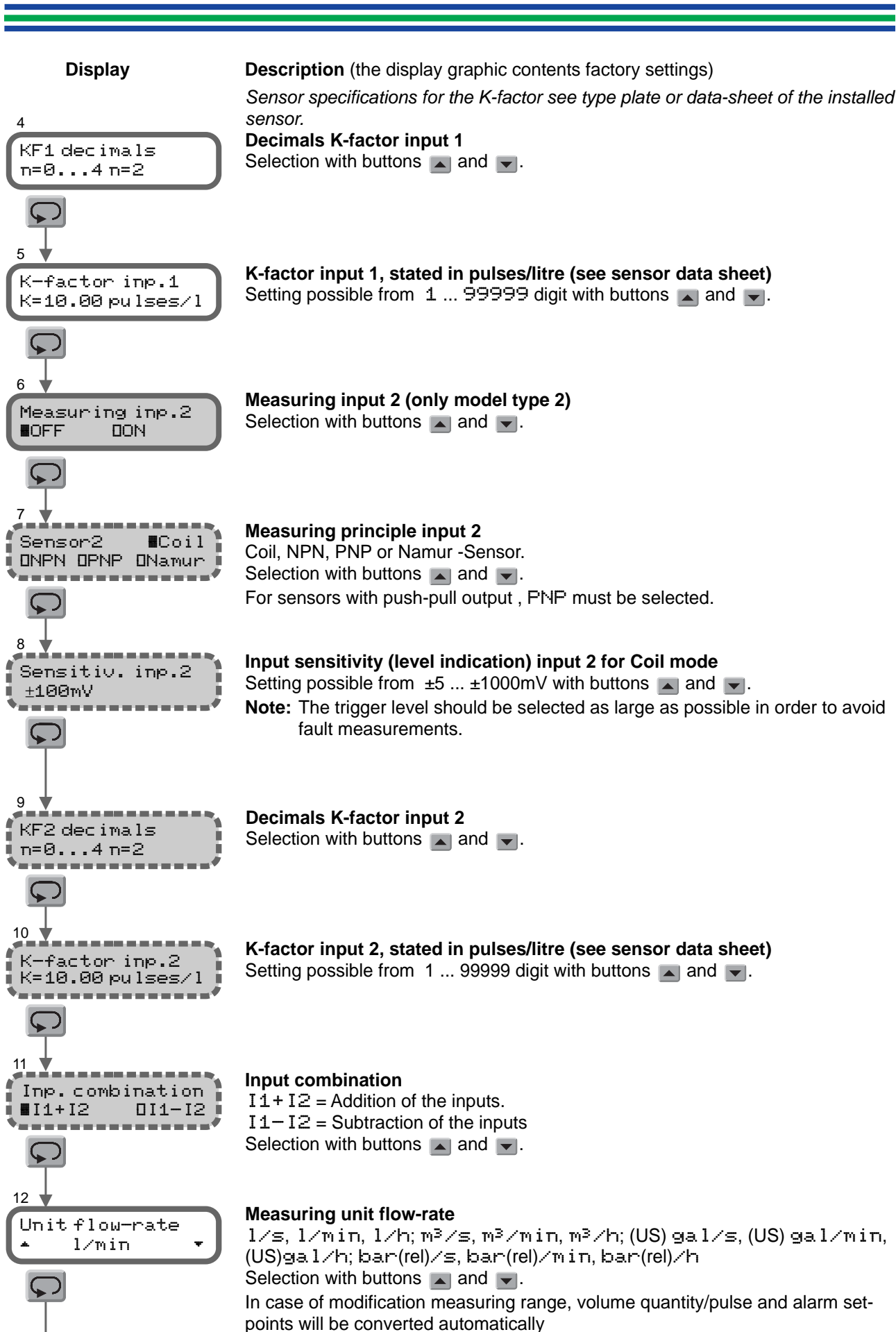

continue page 8

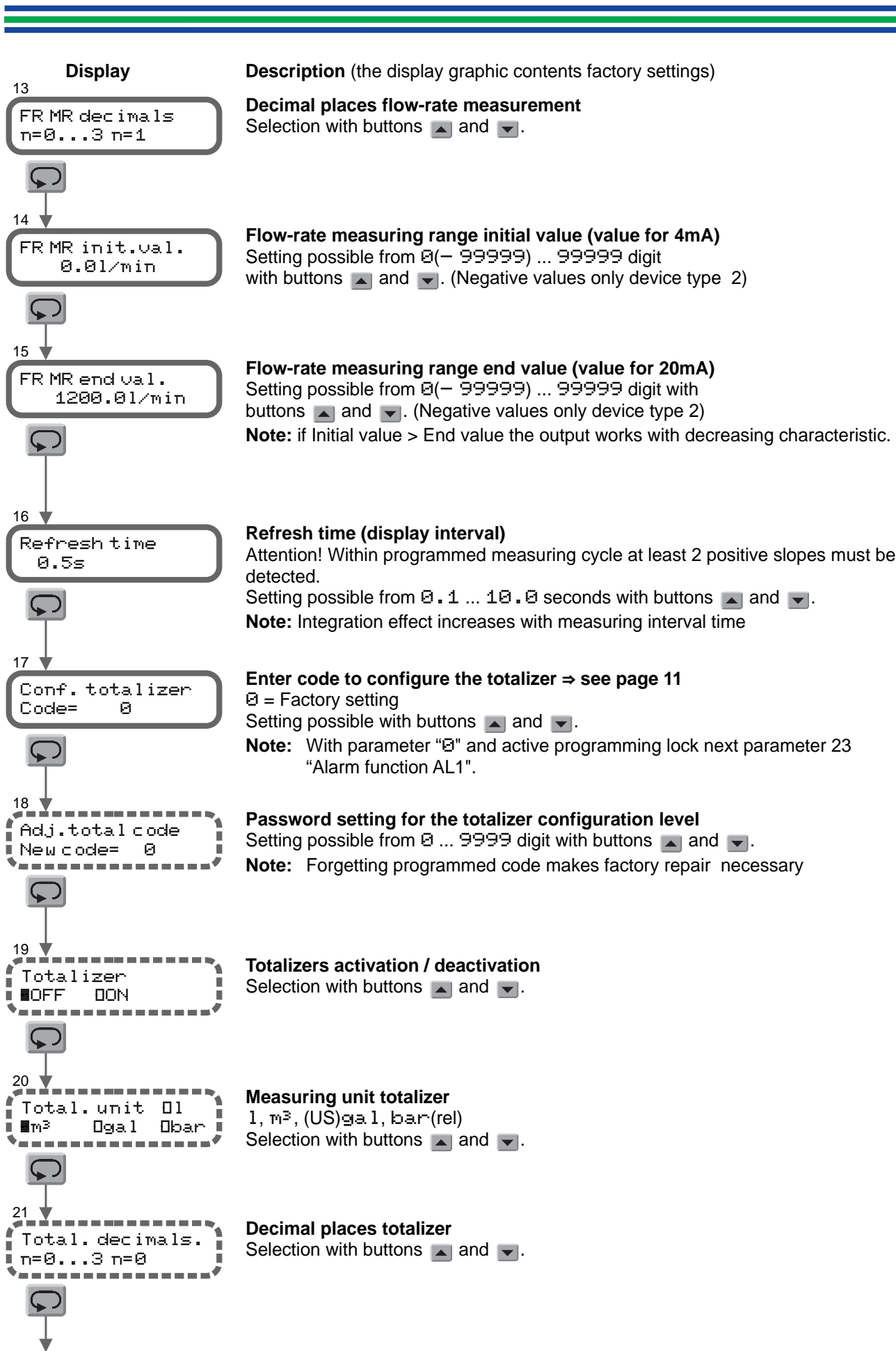

continue page 9

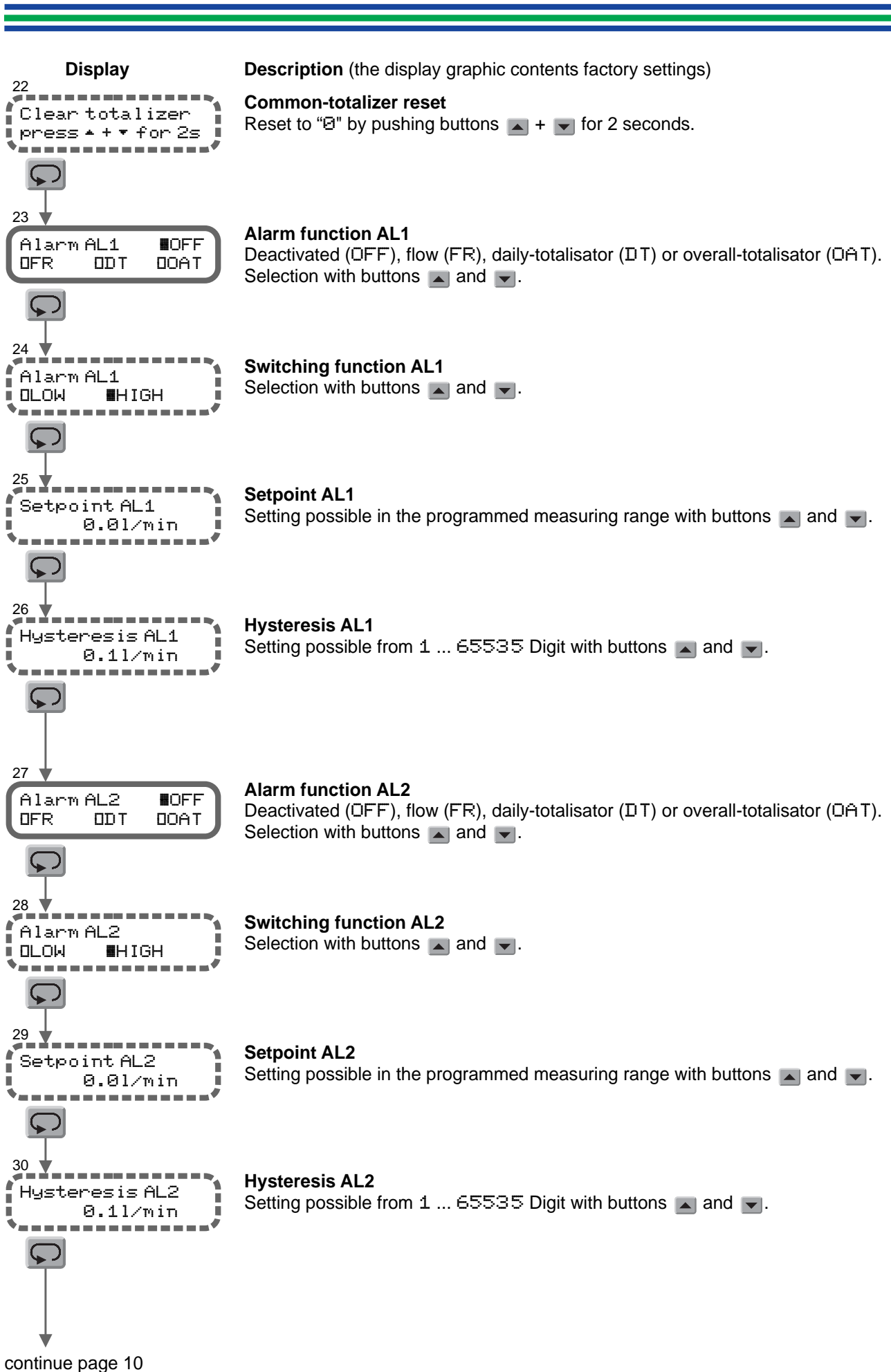

**Description** (the display graphic contents factory settings)

**Common-totalizer reset**

Reset to "0" by pushing buttons ▲ + ▼ for 2 seconds.

**Alarm function AL1**

Deactivated (OFF), flow (FR), daily-totalisator (DT) or overall-totalisator (OAT). Selection with buttons ▲ and ▼.

**Switching function AL1**

Selection with buttons ▲ and ▼.

**Setpoint AL1**

Setting possible in the programmed measuring range with buttons ▲ and ▼.

**Hysteresis AL1**

Setting possible from 1 ... 65535 Digit with buttons ▲ and ▼.

**Alarm function AL2**

Deactivated (OFF), flow (FR), daily-totalisator (DT) or overall-totalisator (OAT). Selection with buttons ▲ and ▼.

**Switching function AL2**

Selection with buttons ▲ and ▼.

**Setpoint AL2**

Setting possible in the programmed measuring range with buttons ▲ and ▼.

**Hysteresis AL2**

Setting possible from 1 ... 65535 Digit with buttons ▲ and ▼.

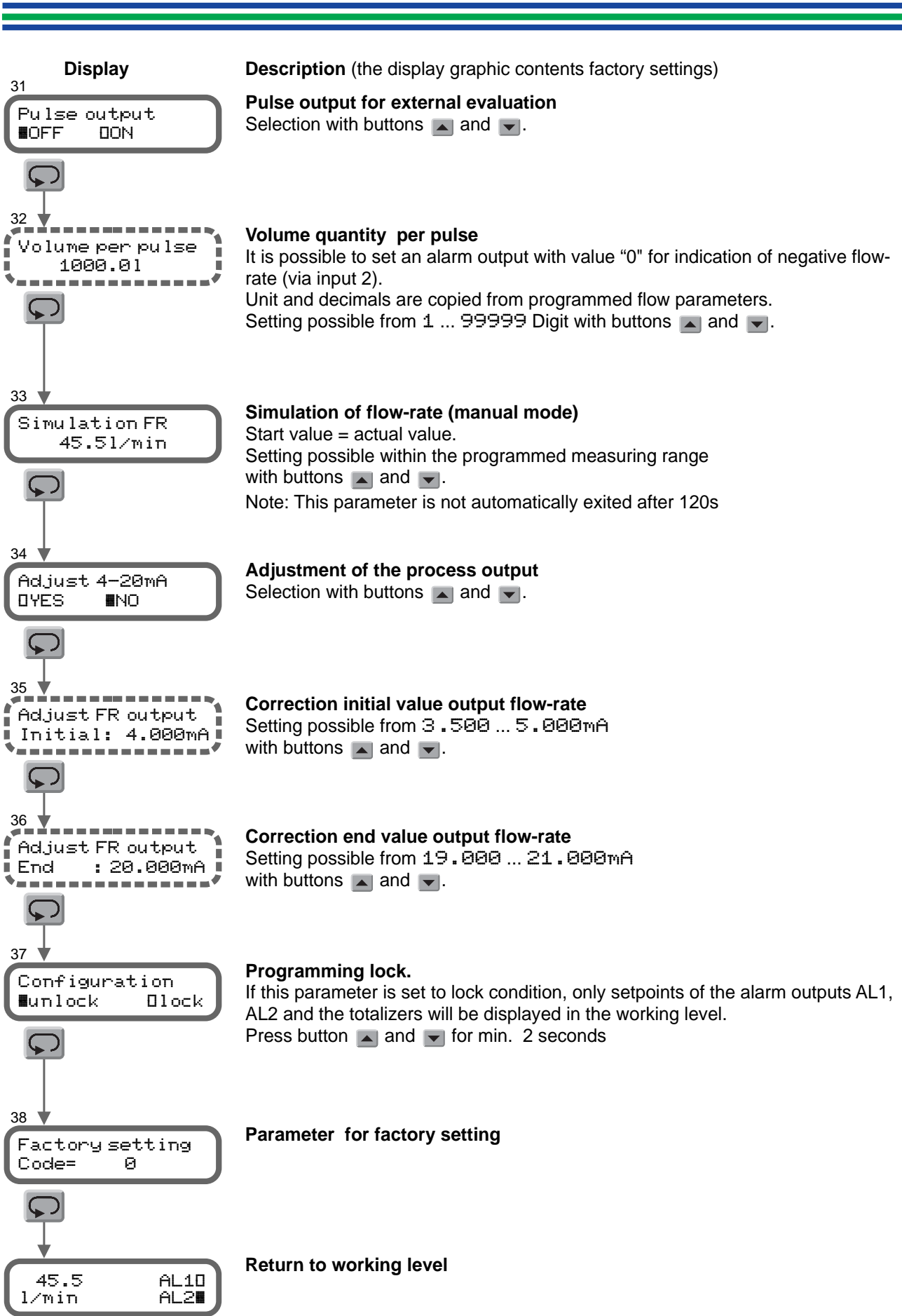

---

---

## Error codes

| Display                             | Description and remedy   |
|-------------------------------------|--|
| Write protect!!                     | An entered parameter data could not be stored because write protection is activated by internal slide switch to position ON. Set switch to position OFF and modify again.  |
| Wrong Code!!                        | Wrong code setting for totalizer programming (Password protection)<br>After approx. 3 s an reset occurs.   |
| XX Param. error<br>please check     | While examination of parameter memory XX errors were detected. Incorrect parameters were put back to factory setting. Check parameters and program again if necessary.   |
| XX Param. error<br>check 4-20mA too | While examination of parameter memory XX errors were detected. Incorrect parameters were put back to factory setting. Check parameters and program again if necessary. However the adjusted values for flow process output 4-20mA must be examined in the factory. |

## Comments to password protection

Access to totalizers can be locked by numeric code (password).

At factory the code is set to "0". Without changing the code, no password protection is active

Entering a 4-digit number (password) in parameter 18 "Adj. total code" will activate password protection.

Now calling again the totalizer parameters is only possible when entering the password in the menu "Konf. Totalisat."

If working again with code number 0, programming continues with next step not concerning totalizer functions.

Entering a wrong code number, display shows "Wrong code". After 3 seconds the device will be reset. Configuration must be started again.

### Attention!

Forgetting the password code makes factory repair necessary!!

## Ordering code:

UNICON-DF -  1. -  2. -  3.

### 1. Model

1 Measuring principle inductive sensor (Coil) Namur-sensor,  
NPN- and PNP-sensor (pulses),  
Output 4...20mA,  
1 impulse output for extern evaluation,  
2 electronic alarm outputs,  
Supply voltage 12 ... 30V DC, loop powered

2 Feature as before, but  
additional input for addition / subtraction,  
(incl. 2-nd cable gland M12x1.5 in the housing)

### 2. Mounting

02 Field mounting  
Connection of the flow sensor with separate connection cable

### 3. Options

00 without option