

VHS... Screw Flow Meter



- Designed for high flow of fluid with high viscosity (up to 2 1/2 " size)
- Up to 350 bar working pressure
- Operation almost independent of viscosity
- Light and compact design
- For cost sensitive application (Aluminum housing standard)
- Bi-directional operation

Application

The flow rate transmitter VHS was especially developed for the metering of viscous fluids. The unit works volumetrically according to the principle of screw transmitters highly accurate and independent of viscosity.

Principle

The medium passes a defined admission bore to get into the flow chamber and causes the revolution of the two screws mounted here. The revolutions are detected by a magnetically biased Hall sensor outside the flow chamber. Additional magnets in the flow chamber are not required. The volumetric displacement by one screw corresponds to two pulses per turn.

This volumetric function of the unit causes an operation independent of viscosity up to 40.000 mm²/s (cSt).

Attention! The units can only be used for lubricating substances to be measured.

The normal transmitter with block plug already has a push pull output to serve all NPN or PNP Inputs. It supplies a square wave signal.

Those transducers are provided with the following functions:



VHS

Frequency output (rectangular), corresponds direct to the screw.
Push pull output (fits to any PNP or NPN input)



M12x1 plug available too.



VHS plus EFFI
F/I: 4...20mA

VHS plus EFFU
F/U: 0...10V

VHS plus EFFF
F/F: 0...2kHz
(programmable)

VHS plus EFFS
F/Switch
(programmable)



VHS plus Flex
1 Switch
(programmable)
or frequency output
+ 4...20mA
or 0...10V



VHS plus omni
Graphic Display
2 Switches
(programmable)
+ 4...20mA
or 0...10V
Programmable on site
with program ring!
Turn able electronic

Please see additional data sheets (EFF/I/U/F/S, Flex-VHS, omni-VHS)

Digital program interface and software to set additional parameters are available.

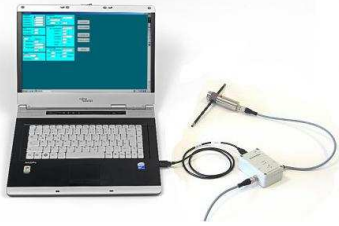

Installation

Any installation position is possible and the flow direction is independent.

Take care of a clean pipe line. Avoid abrasive parts in liquid (if a filter is in line, take a 30 µm mesh).

Fastening must be done without fridge or stress from the tube interface. If it is necessary, use a tube clamp system for the housing of the VHS.

Changing of electronic sensors is possible with active flow and active working pressure (**sensor never has contact to the flow chamber**).

Circuit diagram

Push pull to PNP

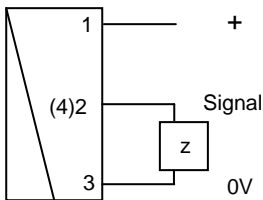

Push pull to NPN

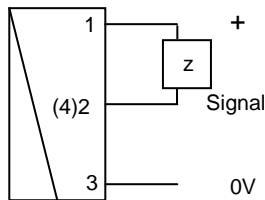

z = load

Please ensure that the correct power supply is used before you connect the device.

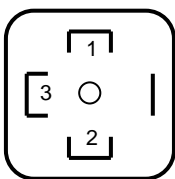

1 +10..30VDC
2 signal out
(4) signal out in case of M12x1plug
3 0V

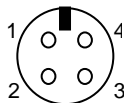

The "push pull output" corresponds to any PNP or NPN Input

Functional data

Range (nominal) l/min	VHS 1	= 1,4...140
	VHS 1 ¼	= 3,5...350
	VHS 1 ½	= 8,0...800
	VHS 2	= 15...1500
	VHS 2 ½	= 25...2500
Please see table at chapter dimension		
Accuracy	1% MV in reference to	

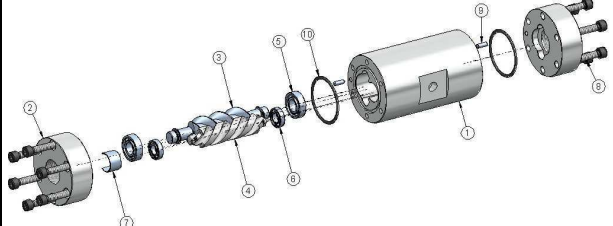
	20 mm ² /s (cSt) please see diagrams below; refer to 1% ...100% of nominal range
Reproducibility	0,25%
Op. Pressure	<u>body port flange pressure</u> Al Al - 160 bar Al steel - 350 bar Al Al SAE 350 bar other materials on request
Over pressure	1.5x op.pressure
Fluid	oil , or viscose self lubricating fluids, not aggressive, no water parts
Fluid temperature	-25 bis +80°C (150°C on request)
Materials	Parts in contact with media Standard in bold letters:
	
1 Body	Aluminium 6082 anodized , cast iron
2 Ports	Aluminium 6082 anodized , cast iron
3; 4 Screws	Steel 1.4460 , hardened steel, hardened AISI
5; 6 Ball bearing	Steel 1.4460 , s.s. 316, ceramic
7 Bushing	Steel 1.4460 , s.s. 316
8 Fixing screws	Steel 1.4460 , s.s. 316
9 Alignment key	Steel 1.4460
10 O-ring seal	Viton , NBR, EPDM
11 SAE-flange	Steel
12 SAE inter flange	Steel
12 O-ring seal	Viton
13 Fixing screws	Steel nickel coated
Supply voltage	10-30V DC
Power consumption	19mA (without load)
Output	Frequency out, push pull (fits to all NPN or PNP inputs), 200mA max, short circuit protected, reverse power protected.
Electric connection	plug, DIN 43650-A or M12x1 plug
Protection	IP67
Conformity	CE

Functional diagrams

Pressure loss / viscosity / flow rate

The pressure loss is a function of flow rate and viscosity of the substance to be measured. The standard viscosity range should be near max. 100mm²/s (cSt). With the flow rate being near that maximum the pressure loss is approx. 3 bar. A higher viscosity does not impair the operation of the unit. It is simply required that the output of the pump is adapted to the increased pressure loss.

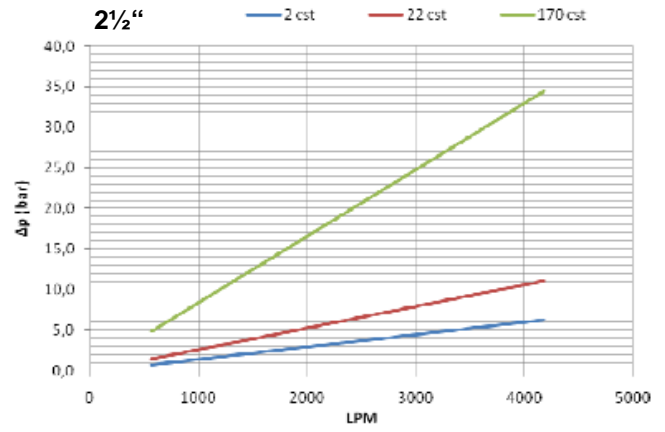
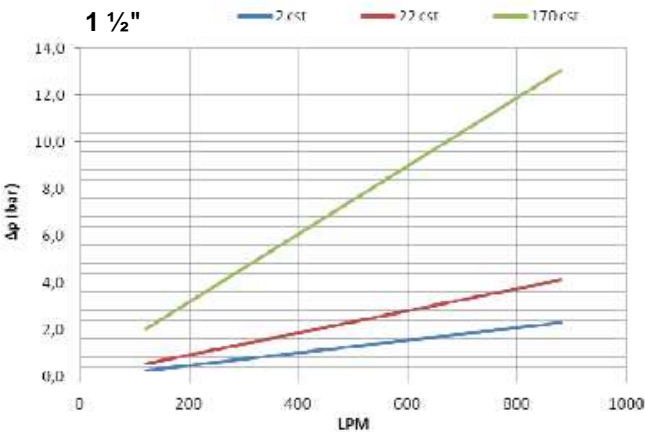
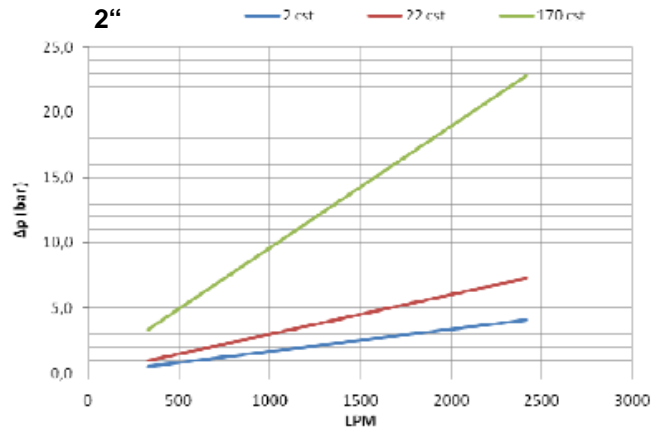
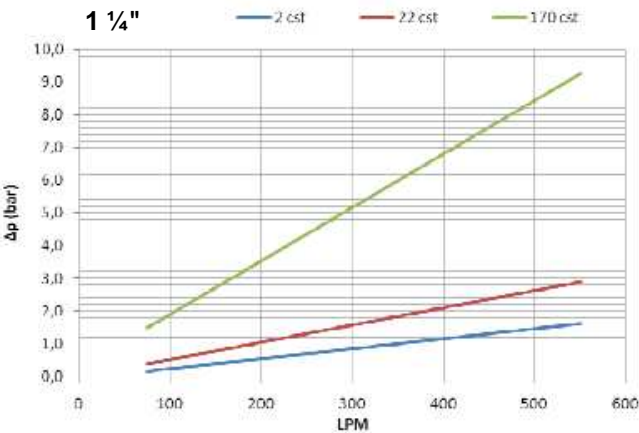
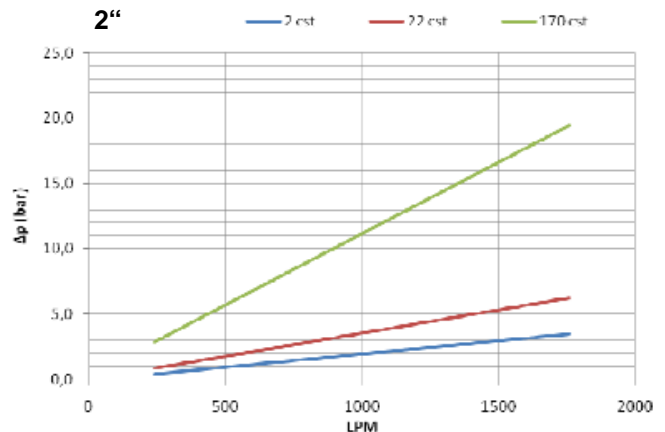
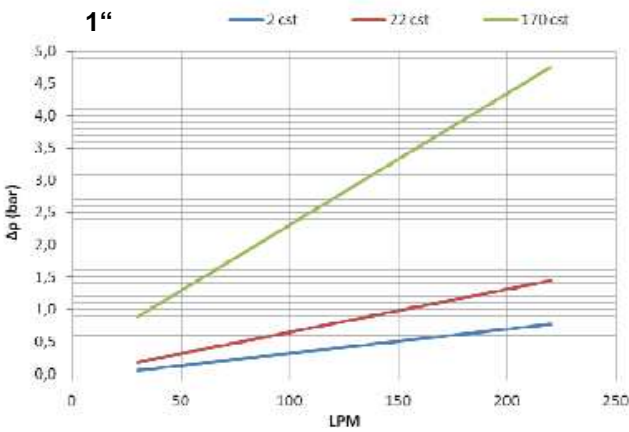
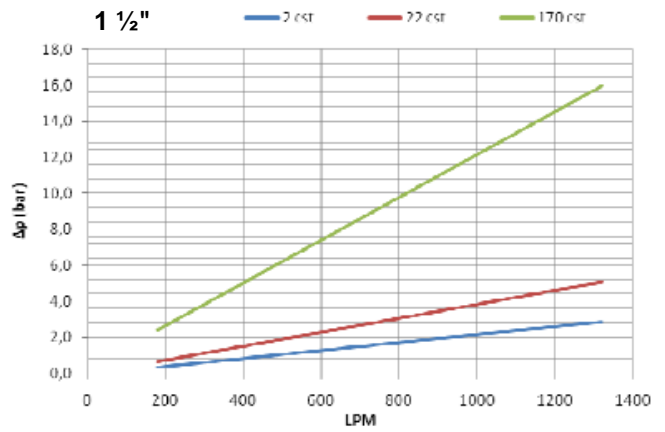

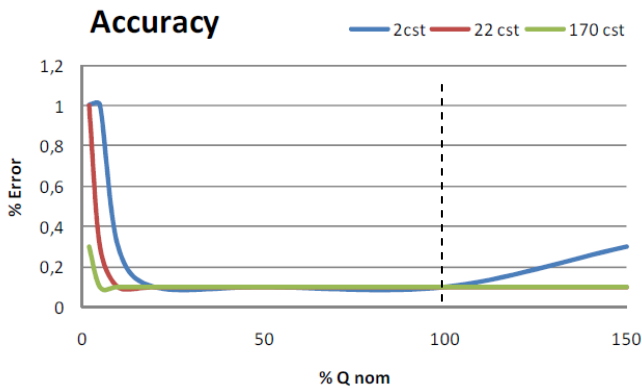
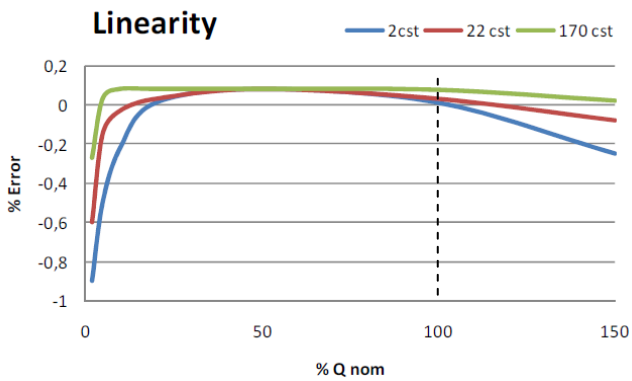

Test viscosity was 2; 22; 170 mm² / s.
 If the measuring range is restricted (e.g. 20%-80% FS), the transmitter operates within narrower tolerances. If the viscosity increase, the accuracy will be better too.

Noise level / flow rate

One of the most important issues of the design was, to create a silent instrument with the VHS. The noise level remains below 50 dB (A). Test viscosity for the diagram is 20mm²/s. If the viscosity increases, the sound level tends to decrease.

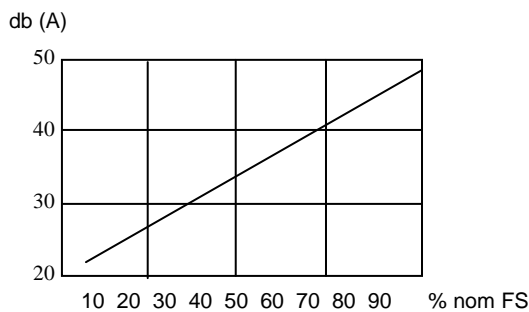

Dimension

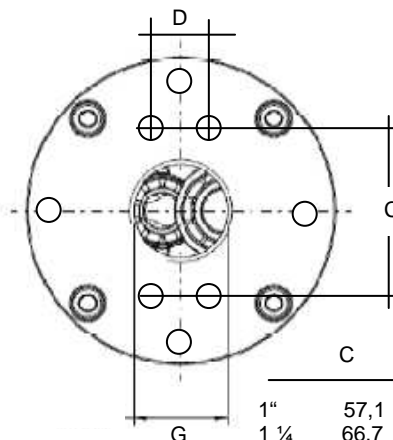
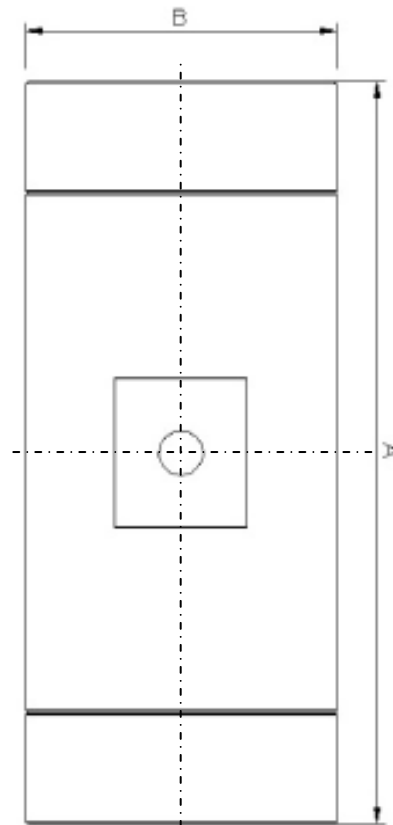

	C	D mm
1"	57,1	27,8
1 ¼"	66,7	31,6
1 ½"	79,4	36,5
2"	96,8	44,4
2 ½"	123,8	58,7

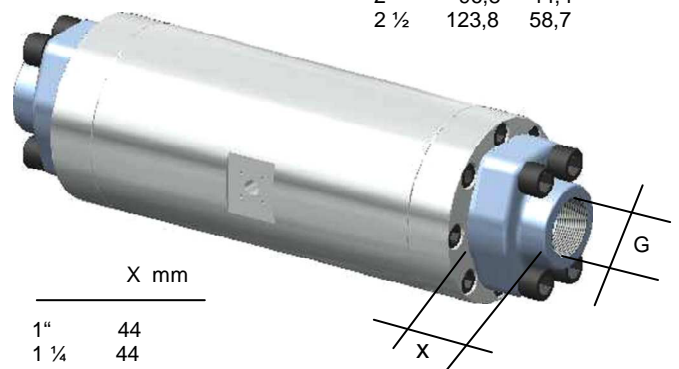

	X mm
1"	44
1 ¼"	44
1 ½"	51
2"	70
2 ½"	75

SAE flange can be added for easier installation and for increasing the operational pressure limit.

Type	Qnom (l/min)	Qmax (l/min)	cc	RPM max	Pulse/liter	Sensor Frequency (Hz) @ Qmax	A	B	Screw	BSPP/Rp Port	SAE /Rp Flange
VHS025	140	200	26,2	7634	76,3	254,5	220	88	6xM8	1"	1"
VHS032	350	500	58	8621	34,5	287,4	270	100	8xM8	1 ¼"	1 ¼"
VHS040	550	800	97,15	8235	20,6	274,5	320	115	8xM10	1 ½ "	1 ½ "
VHS040	800	1200	144	8333	13,9	277,8	340	135	8xM12	1 ½ "	1 ½ "
VHS050	1000	1600	207,26	7720	9,6	257,3	400	160	8xM14	2 "	2 "
VHS050	1500	2200	266	8271	7,5	275,7	430	180	8xM16	2 "	2 "
VHS065	2500	3800	477,63	7956	4,2	265,2	478	210	6xM20	2 ½ "	2 ½ "

Nomenclature

Screw meter

VHS-	025	G	A	X	A	0140	V	B		●	Sample
	025									●	1"
	032									●	1 ¼"
	040									●	1 ½"
	050									●	2"
	065									●	2 ½"
		G								●	Female thread (parallel, G = BSPP)
			A							●	Port, AL anodized (160 bar, in combination with SAE flange 350 bar)
			S							○	Port, steel (350 bar)
				X						●	SAE flange, steel (350 bar)
					O						No SAE flange (have a look to working pressure above!!)
						A				●	Body AL anodized
							0140			●	Flow range, nominal l/min (max and min, please see in table above)
							0350			●	"
							0550			○	"
							0800			●	"
							1000			○	"
							1500			●	"
							2500			●	"
								V		●	FKM (Viton)
											others
									B	●	Frequency output (push pull) plug DIN 43650
									S	○	Frequency output (push pull) plug M12x1
										●	Interface to special electronics like EFF..., Flex..., Omni.. AB outputs, high temperature electronic (150°C), please see separate data sheets and nomenclatures.
									E	●	High temperature Sensor S, with 30mm extended electronic
									H	○	High temperature Sensor S, with 30mm extended electronic

Cable / Plug

K04	PU-	02	S	G		basic type specification
K04					●	ready-made cable 4-pole
KB04					●	connector without cable 4p.
	PU-				●	material PUR
		02			●	length 2 m
		05			●	length 5 m
		10			●	length 10 m
			S		●	shielding connected
			N		○	shielding not connected
				G	●	straight plug
				W	●	angled plug 90°



