



- * gear wheel flowmeter
- * operation independent of viscosity
- * analogue output, switching outputs
- * clear, easily readable, backlit LCD display
- * changeable units in the display
- * designed for industrial applications
- * small and compact
- * most simple installation

PRINCIPLE

Gear wheel flow meter, with provides a linear frequency signal by flow proportional revolution of a gear wheel and sensing by a field biased Hall sensor. Viscosity compensated by volumetric operation.

Please take all additional data from the omni-sensor-family 51.1.omni and data sheet 51.1.omni2.

TECHNICAL DATA

measurement range	in different types 0.02..150 l/min (please see data sheet 6.1.VHZ.)
accuracy	see product information
operating pressure	6.1.VHZ.
operating temperature	0..70°C (goose swan-neck max.80°C)
storage temperature	-20..80°C
supply voltage	18..30 VDC
power consumption	<1 W
output	4(0)..20mA, 2(0)..10V across 500 Ohm resistor to 0V.
switching values S1 and S2	PNP or NPN selectable, 300mA load in sum max., programmable as min. or max. value, short-circuit proof, reverse-polarity proof
hysteresis	adjustable, position of hysteresis depends on min or max.
display	graphical LCD display extended temperature range -20..70°C, 32x16 pixels, back-lit, shows value and units, LED signalling lamp with simultaneous message in display.

connection	at locking plug M 12x1, 5-pole	
protection class	IP67	
materials	housing	stainless steel 1.4305
electronic housing	glass	tempered mineral glass
	magnet	cobalt samarium
	ring	POM

Please take all additional data from 6.1.VHZ.

TERMINAL ASSIGNMENT

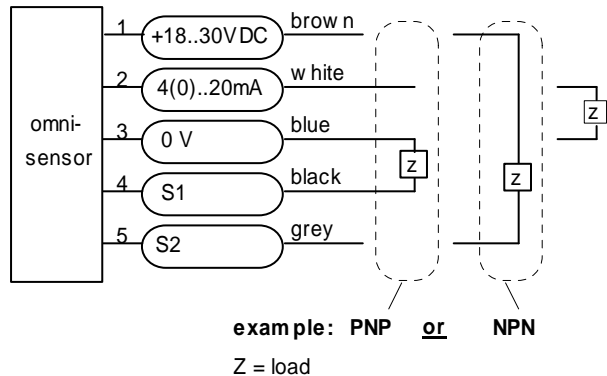

The switchpoints are changing to PNP or NPN depending to your interface automatically (Push-Pull).

Signal output with 2(0)..10V

Sample:

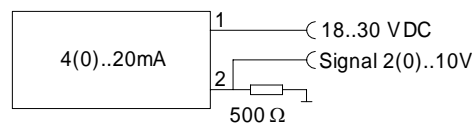

MOUNTING

The converters are connected by plugs to the flowmeter. There is no electrical connection between the local electronics and the flowmeter. Please note that the flowmeter and the smart electronics are paired to one another (same production number) and please follow the mounting instructions for the relevant primary sensor or Flowmeter.

omni-VHZ008 / omni-VHZ010

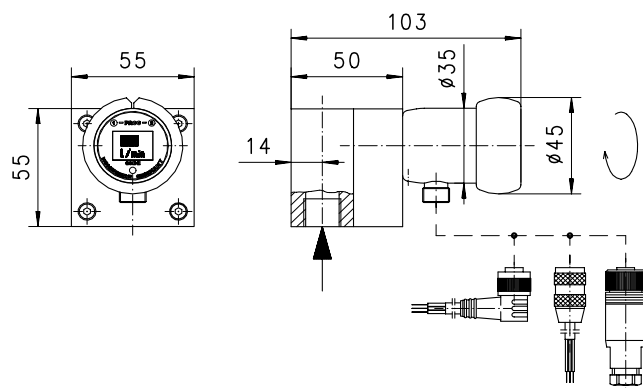

assembly dimensions see product information 6.1.VHZ.

omni-VHZ-020

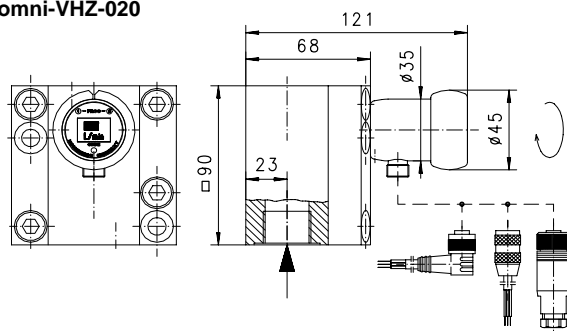

assembly dimensions see product information 6.1.VHZ.

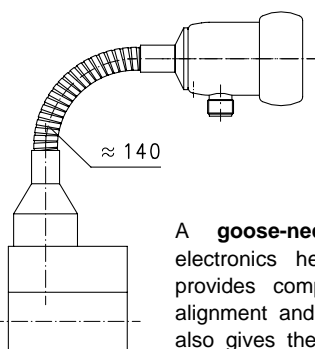

A **goose-neck** (optional) between the electronics head and the primary sensor provides complete freedom in the sensor alignment and reading direction. This option also gives thermal decoupling between both units.

omni-VHZ-025

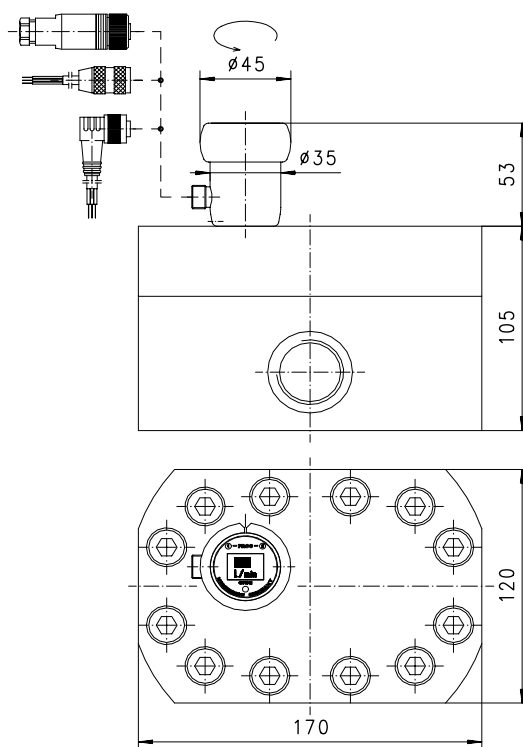

assembly dimensions see product information 6.1.VHZ.

NOMENCLATURE

omni-VHZ	008	S		basic type specification
	008			● DN 8
	010			● DN 10
	020			● DN 20
	025			● DN 25
		S		● connection for locking plug M12x1 , 5-pole
			H	○ goose-neck

IMPORTANT ORDER DETAILS

- the primary sensor is ordered as follows, e.g. VHZ-010... with omni-VHZ010S...

ACCESSORY

Locking plug M12x1

K5	PU-	02	S	G	basic type specification
K5					● ready-made cable 5-pole
KB05					● self makable cable 5-pole
	PU-				● material PUR
		02			● length 2 m
		05			● length 5 m
		10			● length 10 m
			S		● moulded-on plug
				G	● straight plug
				W	● angled plug 90°



All technical changes reserved

●BASIC Standard ○BASIC Programme option □VARIO Special option ⊕ PLUS Accessories ✗not recommendable