



- * universal turbine flowmeter
- * analogue output, switching outputs
- * clear, easily readable, backlit LCD display
- * changeable units in the display
- * designed for industrial applications
- * small and compact
- * most simple installation

PRINCIPLE

The circuitry of the omni is able to detect, display and convert the measuring values of the flowmeter (5.1.RRT.) .

Please take all additional data from the omni-sensor-family 51.1.omni and data sheet 51.1.omni2.

TECHNICAL DATA

measurement range	in different types 1..80 l/min (please see data sheet 5.1.RRT.)
accuracy	see product information
operating pressure	5.1.RRT.
operating temperature	0..70°C (with goose-neck max.90°C)
storage temperature	-20..80°C
supply voltage	18..30 VDC
power consumption	<1 W
output	4(0)..20mA, 2(0)..10V across 500 Ohm resistor to 0V.
switching values S1 and S2	PNP or NPN selectable, 300mA load in sum max., programmable as min. or max. value, short-circuit proof, reverse-polarity proof

hysteresis	adjustable, position of hysteresis depends on min or max.
display	graphical LCD display extended temperature range -20..70°C, 32x16 pixels, back-lit, shows value and units, LED signalling lamp with simultaneous message in display.
connection	at locking plug M 12x1, 5-pole
protection class	IP67
materials	housing stainless steel 1.4305
electronic housing	glass tempered mineral glass magnet cobalt samarium ring POM

Please take all additional data from 5.1.RRT.

TERMINAL ASSIGNMENT

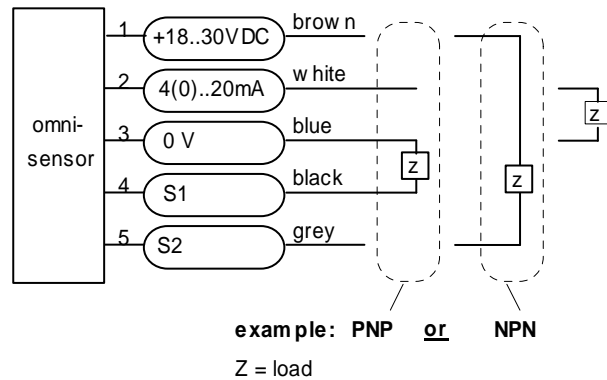

The switchpoints are changing to PNP or NPN depending to your interface automatically (Push-Pull).

Signal output with 2(0)..10V
Sample:

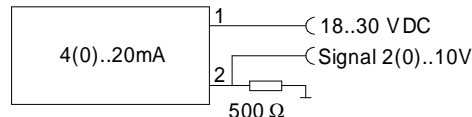

MOUNTING

The converters are connected by plugs to the flowmeter. There is no electrical connection between the local electronics and the flowmeter.

Please note that the flowmeter and the smart electronics are paired to one another (same production number) and please follow the mounting instructions for the relevant primary sensor or Flowmeter.

DIMENSIONS

locking plug M12x1, 5-pole (accessory)

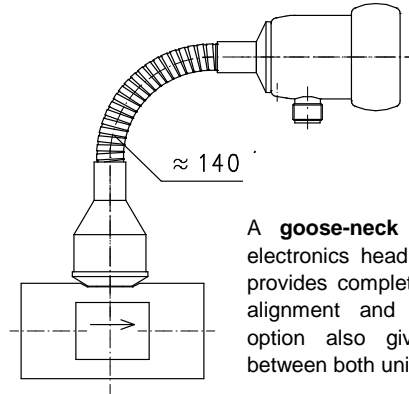
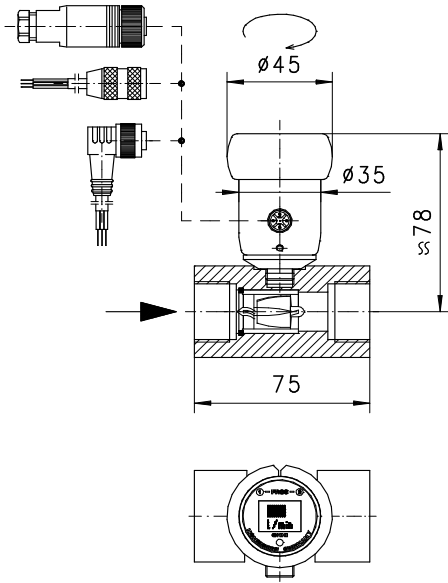

A **goose-neck** (optional) between the electronics head and the primary sensor provides complete freedom in the sensor alignment and reading direction. This option also gives thermal decoupling between both units.

assembly dimensions see product information 5.1.RRT.

NOMENCLATURE

omni-RRT	S		basic type specification
omni-RRT		●	omni at flowmeter RRT...
	S	●	connection for locking plug M12x1, 5-pole
		H ○	goose-neck

IMPORTANT ORDER DETAILS

- the primary sensor is ordered as follows, e.g. RRT-015...with omni-RRTS.

ACCESSORY

Locking plug M12x1

K5	PU-	02	S	G	basic type specification
K5					● ready-made cable 5-pole
KB05					● self makable cable 5-pole
	PU-				● material PUR
		02			● length 2 m
		05			● length 5 m
		10			● length 10 m
			S		● moulded-on plug
				G	● straight plug
				W	● angled plug 90°



All technical changes reserved

●BASIC Standard ○BASIC Programme option □VARIO Special option ⊕ PLUS Accessories ✗ not recommendable