



## Magnetic-Inductive Flowmeters MID1... Family



## General Information

The "magnetic-inductive flowmetering" technology has been used successfully in the industry for many years. Up to now, this technology has been too costly for easier applications.

The new **cost-efficient magnetic-inductive flowmeters made by Honsberg** have changed this drastically.

The **advantages of the magnetic-inductive flowmeter** (German: Magnetisch Induktiver Durchflussmesser - MID) are now available for easier applications, too:

- No moving parts inside the measuring tube.
- Least influence on the cross-sectional flow area, hence lowest pressure loss across the sensor.
- Measurement is independent on temperature, viscosity, concentrations, and pressure.
- Chemical compatibility is only dependent on the resistivity of the electrodes and on the measuring tube.
- Insensitivity to foreign matter carried along in the liquid.
- The flow can be measured irrespective of the flow profile, whether laminar or turbulent.

### Limitations:

- Only conductive substances (50 µS minimum conductivity in this case) can be measured. Air inclusions adversely affect the measurement (therefore, vapour phases cannot be measured).
- Deposits on the electrodes or in the measuring tube may cause measurement errors.

In order to satisfy our customers' different requirements, the magnetic-inductive **flowmeters MID1... are offered in an entire product family.**

Honsberg offers the customer what he needs. Due to the modular system, the MIDs are **configured according to customer's wishes and not custom-developed.**

### Select the correct transducer on the primary sensor!

- With **EFF**, any frequency range may be requested (favourable when replacing turbines. The frequency of the old turbine can be directly substituted.)
- With **EFI** or **EFU**, you have the option to choose analogue **currents** or **voltages** proportional to the flow rate for your PLC.
- **EFS** gives you the opportunity of direct switch point programming (with ON delay, OFF delay, special hysteresis, power-on delay..., if wanted).
- The **omni electronic module** offers you all possibilities of a complete transmitter and switching device with a display able to graphic representation that is readable both in bright daylight and in darkness and that will convince you not with hieroglyphics, but with plain text!

Separate data sheets relating to the omni, Flex, EFF, EFI, EFU, EFS transducers provide comprehensive information on the full scope of use.

## How does a magnetic-inductive flowmeter work?

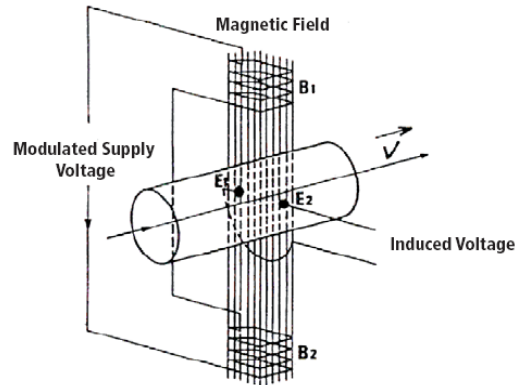

An inductive flow meter consists of an electromagnet and two electrodes that are insulated from the measuring tube wall.

According to Faraday's law of induction, the voltage  $U$  can be picked off at the two electrodes ( $E_1$  and  $E_2$ ), opposite and perpendicular to the flow (see sketch above), when a liquid flows through the measuring tube. For a rotationally symmetrical flow profile and a homogeneous magnetic field, this voltage is directly proportional to the mean flow velocity  $v$  ( $k$ : proportionality coefficient):

$$U = k \times B \times D \times v$$

The flow rate  $Q$  can be calculated from the tube section  $D$  and the mean flow velocity  $\bar{v}$  :

$$Q = \frac{\pi D^2}{4} \bar{v} = \frac{\pi D}{4k B} U$$

Using this method, an electrical signal can directly be obtained from the flow rate and processed further. This results in a strictly linear relationship between the flow velocity  $\bar{v}$  and the induced voltage  $U$ , both for a laminar and turbulent flow.

### Particular features of the present sensors

The method used here works with a pulsed DC field and is thus able to arithmetically suppress originating interference voltages.

The rectangular flow conditioning minimises the rotation of the flow in the measurement channel, thereby permitting a somewhat more unproblematic flow conditioning on the upstream side of the sensor. The bar-shaped electrodes provide higher leakage protection in case of hydraulic shocks as well as better self-cleaning by the flow.

Please observe the notes in the technical data sheets; the MID1... will then serve you for a long time and with constant accuracy.



- For all conductive liquids
- No moving parts inside the measuring tube
- High overload protection
- Low pressure loss
- Compact design
- Different nominal diameters

## Benefit

The MID1 system consists of a number of sensors that measure the flow velocity of a liquid according to the principle of Faraday's law of induction. For this purpose, the liquid must have a minimum conductivity of 50  $\mu$ S. Dependent on the cross-section of the measuring tube, the velocity is converted into a flow volume. Three different nominal diameters are available. The sensors may be supplied with distinct signal-evaluation electronics that differ in the type and number of outputs and in their ease of operation.

## Programming

Adjustment of all parameters is done by means of a PC including a HONSBERG interface. In addition, "teaching" of individual parameters is possible for the MID1 and Flex series. In case of MID1 sensors, this is accomplished via one strand of the connection cable, in case of Flex devices by means of a magnet included in the delivery. For "omni" devices, many parameters can be set by means of a detachable adjusting ring and the integrated LC display.

All sensors are delivered with pre-settings according to customer's demand so that there is no need for reading voluminous manuals prior to commissioning into service.



**MID1-P...AM**  
Frequency output with fixed frequency  
Status display via LED  
(no adjustments possible)



**MID1-P...AF** Frequency output (adjustable)  
**MID1-P...AS** Switch point output (min/max)  
**MID1-P...AU** Analogue voltage output  
**MID1-P...AI** Analogue current output (all design types with LED status display, adjustments via HONSBERG interface / configurator)



**Flex-MID1**  
Frequency output (adjustable) or switch point output (min/max) and analogue output (0...10 V or 4...20 mA)



**omni-MID1**  
Analogue output (0...10 V or 4...20 mA) and 2 switch point outputs (min/max)

Adjustments via programming ring on the device  
Status display via LCD and LED

For further details on the Flex and omni device series, please refer to the appropriate data sheets.

## Installation

The R threads fit into every G inch thread and seal it without any sealing materials (such as Teflon tape). Strong friction on the connecting pieces has to be avoided.

In order to obtain the levels of accuracy indicated in the specifications in practice as well, an inflow and outflow section of 10 x D each should be observed. Always install the flow meters upstream, not downstream a valve (on the pressure side). Good bleeding and an operation free of air bubbles must be provided for.

Prior to electrical connection make sure that the power supply corresponds to the values indicated in the specifications.

All other information on the electronic module can be found in the respective EF..., Flex..., omni.. electronics description.

Magnetic-Inductive

**S**pecifications

<b>Measuring ranges</b>	R1/4"	0.05 ... 1 l/min
	R1/2"	0.5 ... 10 l/min
	R1"	3 ... 60 l/min
<b>Accuracy</b>	R1/4"	0.5 % FS at 0.05 ... 0.2 l/min 2.5 % MV at 0.2 ... 1 l/min
	R1/2"	0.5 % FS at 0.5 ... 2 l/min 2.5 % MV at 2 ... 10 l/min
	R1"	0.5 % FS at 3 ... 12 l/min 2.5 % MV at 12 ... 60 l/min
<b>Minimum conductivity (medium)</b>	50 µS	
<b>Working pressure</b>	max. 10 bars	
<b>Working temperature</b>	0...60 °C (avoid frost and dew)	
<b>Medium temperature</b>	0...60 °C	
<b>Storing temperature</b>	-20...80 °C	
<b>Pressure loss</b>	max. 0.3 bar at max. flow	
<b>Supply voltage</b>	12...24 V DC	
<b>Power consumption</b>	approx. 100 mA	
<b>Connection</b>	Circular connector M12x1	
<b>Materials (with contact to medium)</b>	Stainless steel 1.4404 PPS, FKM (Viton)	
<b>Materials (without contact to medium)</b>	Ms nickel-plated, PA66, V2A	
<b>Degree of protection</b>	IP 64	
<b>Weight</b>	MID1-P008: approx. 200 g MID1-P015: approx. 200 g MID1-P025: approx. 300 g + Flex head: approx. 120 g + omni head: approx. 150 g	

Legend: FS = Full Scale, MV = Measured Value

**D**imensions

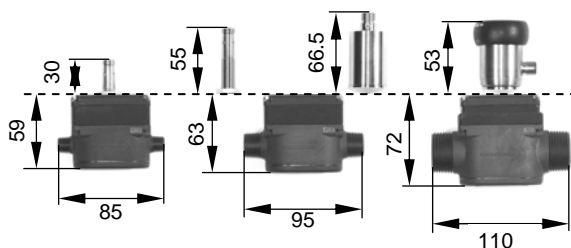

Adapters as accessories on request:

- Female thread G
- Hose adapter
- Ermeto compression joint
- Customer-specific

**T**ype Nomenclature

MID-	P	008	A	M	001	S	Example Description
	P						Casing material PPS
	X						Casing material PEEK (upon request)
		008					Connection R1/4"
		015					Connection R1/2"
		025					Connection R1"
			A				Male thread
				M			Frequency output NPN o.C.
				E			Output via local electronic module (e.g. omni-MID1, Flex-MID1, EFF..)
					001		Range 0.05 - 1 l/min
					010		Range 0.5 - 10 l/min
					060		Range 3 - 60 l/min
						S	Terminal for circular connector M12x1, 4-pin (Version M)

**C**ombinations

Please see separate datasheets with detailed information and nomenclatures:

Omni-Flex-EFF/i/