

GENERAL CHARACTERISTICS

Mechanical Flow Switch for gaseous media, with magnetic triggering of a reed switch. Rugged design in brass.

- * compact dimensions
- * control of small flow rates

Female thread M5 brass



MF-003GM

TECHNICAL DATA

M	Type	PN bar	Qmax. recommended l/min	switch value l/min selectable range for fixed switch	weight kg
brass	MF-003GM	6	air 1bar 20°C 100	air 1bar 20°C 1 - 100	0.06

Switch value is indicated for horizontally decreasing flow.

tolerance ±15% of full scale
media temperature max. 80°C

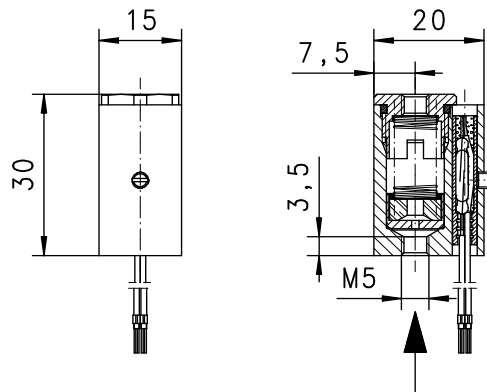

MATERIALS

body	brass Ms58
piston	brass Ms58
spring	stainless steel 1.4310
magnet	bariumferrite
seal	NBR

MOUNTING POSITION

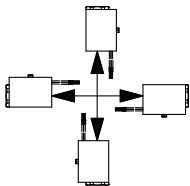

Installation position may influence switch value.

ELECTRICAL DATA

reed switch - wiring 0.212 n.o.
125 V AC 0.5 A 10 VA
connection: two wires 170mm
protection class IP 65

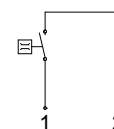

METERING SUBSTANCES



gas/air

NOMENCLATURE

MF-	003	G	M	basic type
		G		specification
			M	● female thread M5
				● brass

IMPORTANT FOR YOUR ORDER

- Please indicate flow direction, metering substance and switch value with your order.
- With gaseous media indicate pressure (relative or absolute), temperature and metering substance (switch value on request)

All technical changes reserved

●BASIC Standard ○BASIC Programme option □VARIO Special option ⊕ PLUS Accessories ✗ not recommendable