



- * flush stainless-steel membrane or ceramic measuring cell
- * switching output and/or analogue output (4..20 mA/0..10 V)
- * IP67 type of protection
- * infinitely rotatable cable outlet for precise alignment
- * robust stainless-steel housing

PRINCIPLE

The pressure gauge of this series measures pressures in liquids and gases. It outputs the measuring result as an analogue signal or signals that a set limit value was exceeded or not reached using an electronic switch. Even combinations of an analogue output and a limit switch are available. The switching output can be designed alternatively as a frequency output. For further options, see page 3. The robust all-metal construction makes it universally applicable in industrial situations.

The primary sensor is available in two different technologies and in various measurement ranges:

Flex-P: A stainless-steel membrane transfers the applied pressure via an oil filling to a monosilicon membrane with a sputtered, piezoresistive measuring bridge made of polysilicon. The stainless-steel membrane is absolutely flush and offers the lowest possible risk of contamination.

Flex-P1: Pressure measurement using an affordable ceramic thick-film cell that is protected from damaged by a non-flush installation and designed to be extremely robust.

In case of designs having a limit switch, the desired limit value is set by activating a magnetic switch using magnetic at the applied limit pressure.

TERMINAL ASSIGNMENT

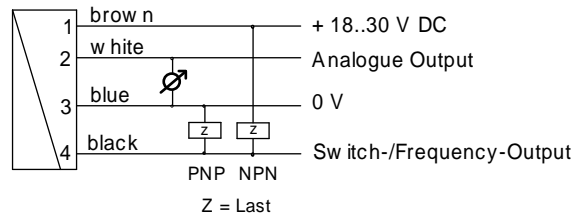

It is recommended to use shielded cable < 30 m, supply lines < 10 m

MOUNTING

The pressure transducers are screwed into a connection piece or T-piece of the pipeline together with suitable sealing material (Teflon tape, Sikurit seal, etc.). The installation of a pressure gauge should not result in any considerable cross-section changes in the pipe system. To tighten the pressure gauge, please use only the fixed spanner provided for this purpose (width against flats of SW27). Avoid high-concussion installation sites (see overload limits). In the case of the high-temperature design with a bendable gooseneck, the pressure gauge can be operated at a media temperature up to 120°C. For this installation, also make sure that the head with the plug is not exposed to more than 70°C.

PROGRAMMING

Designs with a limit switch have a magnetic contact by means of which the current measurement value can be assumed as a limit value. It is programmed by applying a magnet to the marking on the type plate for 0.5 to 2 seconds. If the contact time is too short or too long, no programming will take place (protection against magnetic fields). Immediately after programming, the switching output enters the OK state (LED on, output switched through, e.g. PNP = high or NPN = low).



TECHNICAL DATA

	Flex-P		Flex-P1	
measurement ranges	range	overload	range	burst
relative pressure	0 - 1	4	0 - 1	4
	0 - 2,5	10	0 - 2	6
burst pressure	0 - 6	24	0 - 5	15
	0 - 10	40	0 - 10	40
(in bar)	0 - 25	100	0 - 20	60
	0 - 60	240	0 - 50	150
	0 - 100	400	0 - 100	280
	0 - 250	600	0 - 200 *	400
	0 - 400	600	0 - 400 *	1050
			* for gas applications only on request	
optional	additional measurement ranges absolute pressure metering (low limit 10mbar abs.)		-	
precision	±1% F.S. ; 0.02% /K from 60°C		±1% F.S. ; 0.05% /K at <0° and >60°C	
reproducibility	±0.5% F.S.		±0.1% F.S.	
dynamics	measuring cycle of 50 ms			
working temperature	-20..70°C (as a high-temperature design with goose-neck, max. 120°C)			
storage temperature	-20..80°C			
voltage supply	18..30 VDC			
power consumption	<1 W			
analogue output	4..20 mA or 0..10 VDC			
limit switch	PNP, NPN, or NPN (open collector) available as a minimum or maximum switch Output current, max. 100 mA, short circuit proof, reverse polarity protected The limit value is set by activating an integrated magnet switch using a magnet.			
hysteresis	2% F.S. (full scale), hysteresis above limit value for minimum switch, below limit value for maximum switch			
display	LED indicator lamp in plug outlet (in case of limit switch only)			
connection	at locking plugs M12x1, 4pole			
protection class	IP67			
materials				
in contact with media	stainless steel 1.4301		stainless steel 1.4571, Ceramic Al ₂ O ₃ , Viton	
electronic housing	stainless steel 1.4305			

DIMENSIONS

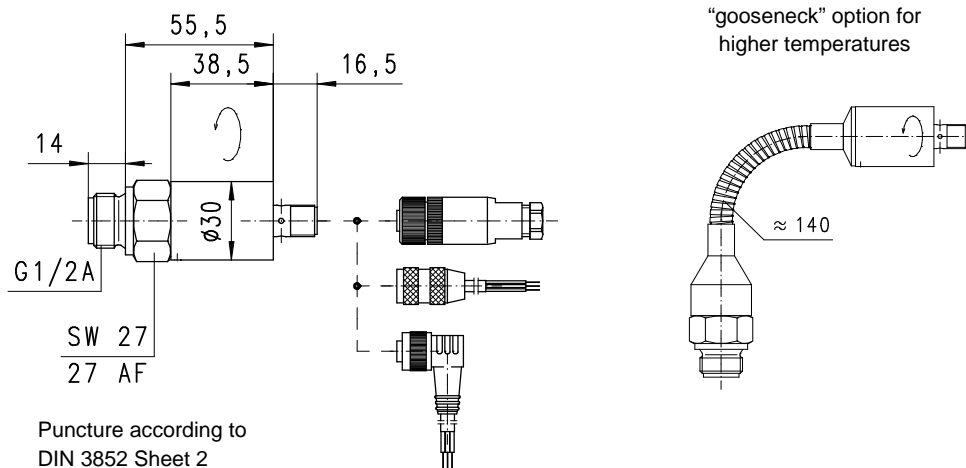

NOMENCLATURE

Example:

Flex-P	001	R	K	015	H	I	P	R	O
A	B	C	D	E	F	G	H	I	J

A sensor family/technology	Flex-P with stainless-steel membrane	●
	Flex-P1 with ceramic measuring cell	●
B pressure measurement range:	xxx pressure range in bar (e.g. 1 bar = 001)	●
C reference pressure:	R relative pressure	●
	A absolute press. (only stainless-steel cell)	○
D material (in contact with media):	K stainless steel 1.4571	●
E connection size:	008 G1/4A (on in case of P1 ceramic cell)	○
	015 G1/2A	●
F type of connection:	H outer thread	●
	I inner thread	○
	L foodgrade connection (tri-clamp)	○
G analogue output:	I current output 4..20 mA	●
	U voltage output 0..10 V	●
	K no analogue output	●
H switching output:	P switching output PNP	●
	N switching output NPN	●
	M switching output NPN (open collector)	○
	K no switching output	●
I switching signal:	L minimum switch	●
	H maximum switch	○
	R frequency output	●
	K no switching output	●
J inversion of output:	O standard output	●
	I inverted output	●

Options:

special range - analogue output: (not greater than the working range of the sensor)	<input type="text"/> <input type="text"/> <input type="text"/> bar
special range - frequency output: (not greater than the working range of the sensor)	<input type="text"/> <input type="text"/> <input type="text"/> bar
end frequency (max. 2000 Hz)	<input type="text"/> <input type="text"/> <input type="text"/> <input type="text"/> Hz
turn-on delay (from alarm to OK)	<input type="text"/> <input type="text"/> s
turn-off delay (from OK to alarm)	<input type="text"/> <input type="text"/> s
power-on delay (time after the supply is created; in this time the switching output is not activated)	<input type="text"/> <input type="text"/> s
switching output with permanent setting	<input type="text"/> <input type="text"/> <input type="text"/> bar
special hysteresis (standard = 2% F.S.)	<input type="text"/> <input type="text"/> %
goose-neck (recommended for application temperatures over 70°C)	<input type="checkbox"/>

In case of empty fields, the standard setting will be selected automatically.

RELATED PRODUCTS



omni-P/P1
Evaluation electronics with backlight LCD, current output, and two electronic limit switches, parametrisable via setting ring gauge

ACCESSORIES

Locking plug M12x1

K	PU-	02	S	G	S	basic type specification
K						● assembled
KB04						● self makable cable 4-pole
	PU-					● material PUR
		02				● length 2 m
		05				● length 5 m
		10				● length 10 m
			S			● moulded-on plug
				G		● straight plug
				W		● angled plug 90°
					S	● shielded



All technical changes reserved

●BASIC Standard ○BASIC Programme option □VARIO Special option ⊕ PLUS Accessories ✗not recommendable