

F30 PUMP CONTROLLER

CAPABLE OF DIRECTLY CONTROLLING PUMPS UP TO 3.75Kw 5HP, THE F30 IS A VERSATILE CONTROLLER THAT INTEGRATES FLOW AND PRESSURE. IT BRINGS THE ADVANTAGES OF CONSTANT FLOW AND DRY RUN PROTECTION TO TRADITIONAL PRESSURE SYSTEMS.

INTRODUCTION

The F30 Pump Controller is a microprocessor based electronic flow switch that monitors both flow and pressure. When included in a pressure system it vastly improves overall performance and gives the benefit of both constant flow and dry run protection.

Pressure systems cycle between low and high pressure, not because this gives the user any advantage but simply because a pressure differential is required to operate the pressure switch that normally controls such pumps. The user sees the effect as fluctuations in pressure at the tap. If loss of prime occurs, a pump controlled by a pressure switch will run the pump dry and can cause major damage.

THE F30 CONTROLLER

The F30 Pump Controller offers a far better approach. The pump starts on either flow or pressure drop, as soon as there is a modest demand. When demand ceases the controller continues to run the pump for a length of time, sufficient to recharge the system's air cell. Such a system allows the selection of a pump that has a flat curve and delivers a steady constant pressure over widely varying flows. An air cell with a very small draw-off can be used; as there only has to be sufficient stored pressure to re-actuate the F30 controller the next time there is a demand. With the F30 system the external pressure switch is set to start the pump at a pressure only marginally higher than the system's static pressure. If the demand is too low to actuate the F30's paddle, or if for any reason the pressure falls, eventually the pressure switch will close and signal the F30 to start the pump. The F30 then runs the pump for a preset time, recharges the air cell, switches to standby mode and waits for a further demand.

DRY RUN PROTECTION

A pump running under the control of an F30 will start if the pressure drops, or if a tap is turned on. If the system runs out of water the F30 senses the loss of flow and the lack of pressure and stops the pump. A red warning light on the controller then flashes rapidly to indicate there is a problem. The pump will not restart until the power to the pump is reset.

CONSTRUCTION

The F30 controllers have no metal parts in contact with liquids. They operate magnetically through a seal-less magnetic coupling system. They are therefore ideally suited to use in aggressive or saline ground water, in seawater or chlorinated water and in a huge variety of chemical solutions, including most acids and alkalis. The F30 is made from a high tech blend of Polypropylene and ABS thermoplastic, specifically tailored to give the highest possible performance, in terms of mechanical strength, ultraviolet stability, and chemical inertness.

INSTALLATION

The F30 pump controller should be mounted in a straight section of the pump's discharge pipe, either before or after the air cell. A 1" BSP female thread must be provided to fit the controller. The F30 is supplied with an extra long paddle to allow it to be installed in large pipes for industrial or irrigation use. The paddle is normally cut down to suit the specific pipe into which the controller is to be installed.



- Run-on Timer Control
- Start-up Timer Control
- Pressure switch LED
- Paddle and Alarm LED
- Timer LED



AUSTRALIAN MADE

TECHNICAL DATA

TYPICAL PRESSURE SYSTEM WITH AN F30 INSTALLED FOR PROTECTION

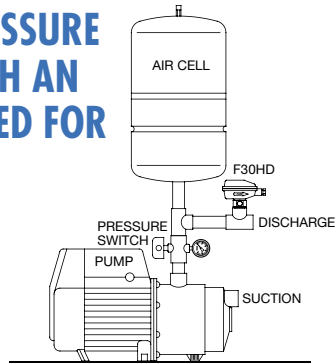

LAYOUT OF A LARGE RURAL OR INDUSTRIAL PUMPING SYSTEM

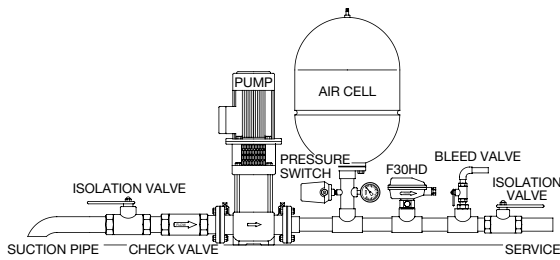

BASIC PRESSURE SYSTEM WIRING DIAGRAM

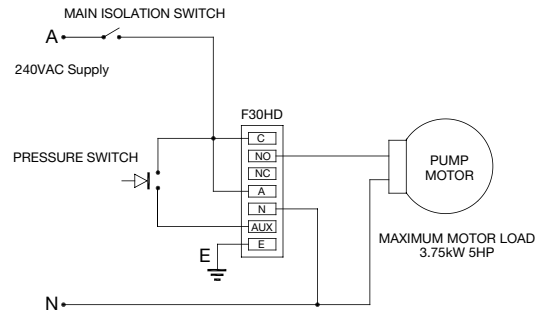

DIMENSIONS

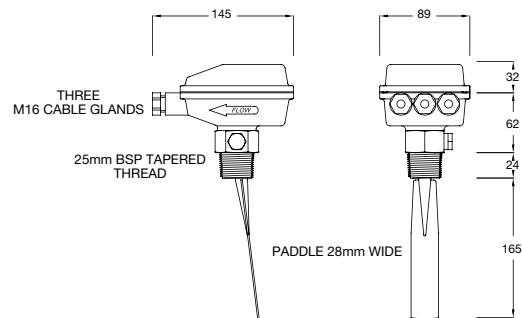

MODELS

Part Number	Maximum 240VAC Motor Load	Supply Required	Contact Type	Typical Application	Output Type	Suitable for general control circuit applications
F30-240HD	3.75kW 5HP	150mA at 240VAC	S.P.D.T.	Control of pump motors to 5HP	Hybrid Solid State Drive	NO
F30-24HD	3.75kW 5HP	150mA at 240VAC	S.P.D.T.	Control of pump motors to 5HP	Hybrid Solid State Drive	NO
F30-240	0.75kW 1HP	150mA at 240VAC	S.P.D.T.	Control of pump motors to 1HP	Mechanical Relay	YES
F30-24	0.75kW 1HP	150mA at 24VAC	S.P.D.T.	Control of pump motors to 1HP	Mechanical Relay	YES
F30-DC	0.75kW 1HP (AC Motors Only)	150mA at 12 to 24VDC	S.P.D.T.	Control of pump motors to 1HP	Mechanical Relay	YES

OPTIONS

316 Stainless steel high pressure body
1" NPT Male process connection
Trailing Wire Sensor for effluent applications

SPECIFICATIONS

Microprocessor digital control.
Pressure switch input. Allows connection of external pressure switch.
Indicator LED shows when the pressure is high or low.
Fully independent control over both the start-up and run-on timers.
Start-up timer adjustable from 0 to 180 seconds.
Run-on timer adjustable from 0 to 300 seconds.
True paddle status LED, turns on and off in response to flow.
Power indication LED blinks to indicate the F30HD is powered up.
Timer LED indicates the start-up timer is running.
Dry run LED flashes to indicate the pump has run dry and shut down.
Timer LED indicates the run-on timer is running.
Output to drive pump is via a Solid State Hybrid Drive or Relay.
Brown-out and voltage surge protection built-in.
Magnetic paddle adjustment for flow sensitivity.
Three M16 cable glands in the controller's housing accept 8mm flex or three M16 conduit connections.
Maximum operating pressure, static or dynamic, standard models 18 Bars (260 PSI). 316 Stainless steel model 100Bars (1400 PSI).
Maximum liquid temperature 70°C.
Minimum liquid temperature -20°C.
Liquid Ph 1 to 14, Standard Polypropylene models.
Maximum ambient temperature 45°C.
Weatherproof rating, housing IP56 Hose-proof.

MADE IN AUSTRALIA BY

KELCO

KELCO ENGINEERING Pty Ltd ABN 20 002 834 844
 Head Office and Factory: 9/9 Powells Road BROOKVALE 2100 AUSTRALIA
 Postal Address PO Box 496 BROOKVALE NSW 2100
 Phone: (61) 2 99056425 Fax: (61) 2 99056420
 Email: sales@kelco.com.au URL www.kelco.com.au

PLEASE NOTE: Kelco Engineering Pty Ltd reserves the right to change the specification of this product without notice. Kelco Engineering Pty Ltd accepts no liability for personal injury or economic loss as a consequence of the use of this product. All rights reserved copyright Kelco Engineering Pty Ltd © 2008