

Media: air – water – light oil - vacuum  
 Pressure range: 0 to 7 bar max  
 Media temperature: 80° C max  
 Ambient temperature: -20° to +60° C max  
 Media viscosity: 50 centistokes max  
 Mounting: coil upright  
 Opening / Closing Time: 50 mSec Max

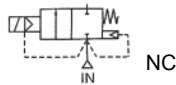

# 2/2 Brass Flanged

N/CLOSED  
 2 WAY ASSISTED LIFT

TYPE UWF



## PRESSURE

Ø Port	Ø Orifice (mm)	Flow Rate Cv Ltr/ min	Pressure Rating (bar)				Seals Temperature °C	Part Number	List Price
			Min ΔP	Max ΔP AC	Max ΔP DC	Max Working			
1/2 ANSI150Lb	15	75	0	7	5	10	NBR 80°C FKM 120°C EPDM 120°C Silicone 130°C	UW15F + seal + voltage	£164.00
3/4 ANSI150Lb	20	143	0	7	5	10		UW20F + seal + voltage	£173.02
1 ANSI150Lb	25	200	0	7	5	10		UW25F + seal + voltage	£182.31
1 1/4 ANSI 150Lb	35	400	0	10	7	10		UW35F + seal + voltage	£259.67
1 1/2 ANSI 150Lb	40	467	0	10	7	10		UW40F + seal + voltage	£264.31
2 ANSI 150Lb	50	800	0	7	5	10		UW50F + seal + voltage	£355.33

## OPTIONS

Connector PG9 – DIN 43650 A IP65 Coil (Optional round coil with 30cm flying leads) ANSI 150Lb flange Explosion Proof Coil: EExmIIT4 ATEX II G IP65 T 130°C (Optional T6 85°C) UW15 to UW25	<b>Included Included Included +£80.38 +10%</b>
---	--

## ELECTRICAL DATA

Voltage (-10% + 10%) Continuous duty 100%	Coil Size	Power		Insulation class	Enclosure	Electrical connections
		Inrush	Holding			
~ 24 - 110 - 230 (50 or 60 Hz)	WPA2	40VA	24.2VA	F 155°C	IP 65 with connector	3 spades DIN 43650A DIN 40050 VDE 0110
= 12 - 24 (DC)		18 Watts				

## CONSTRUCTION

Body: UW 15 – 25 Brass UW 35 – 50 Bronze  
 Tube and internal parts: Stainless steel  
 Seals and gaskets : NBR (Optional EPDM, FKM or Silicone)  
 Moulded coil : Resin

## REPAIR KIT

Diaphragm seal + O Ring	SP215 - 216 + valve part number
Coil	WPA2 + voltage
Complete plunger assembly	SP213-216 + valve part number

## OVERALL DIMENSIONS

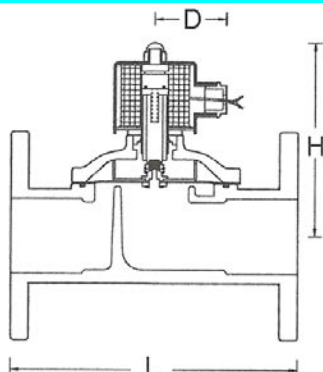

Model	L	H	D	Weight
UW15F	95	100	50	2.1
UW20F	100	102	50	2.6
UW25F	150	106	50	4.3
UW35F	155	140	58	5.9
UW40F	155	140	58	6.8
UW50F	200	170	58	8.8