

Media: air – water – light oil
 Pressure range: 1 to 200 bar max
 Media temperature: 100° C max
 Ambient temperature: -10° to +50°C
 Media viscosity: 40 centistokes max
 Mounting: vertical position, coil up
 Weight (including coil): 430 g
 Opening or Closing time: 100mSec Max

2/2 Brass N/CLOSED

High Pressure 6mm Orifice 2 WAY SERVO ASSISTED

TYPE 206244

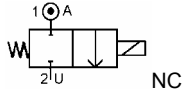

PRESSURE

Ø Port	Ø Orifice (mm)	Flow Rate Cv Ltr/ min	Pressure Rating (bar)			Seals	Max Media Temp °C	Part Number	List Price
			Min ΔP	Max ΔP air	Max ΔP water - oil				
1/8 BSP or 1/4 BSP	6	5.0	1	100		NBR EPDM FKM	60 100 100	20624410 + port + voltage 20624430 + port + voltage 20624420 + port + voltage	£326.75
			1		100	NBR EPDM FKM	60 100 100	20624510 + port + voltage 20624530 + port + voltage 20624520 + port + voltage	
			1	200		NBR EPDM FKM	60 100 100	20624610 + port + voltage 20624630 + port + voltage 20624620 + port + voltage	
			1		200	NBR EPDM FKM	60 100 100	20624710 + port + voltage 20624730 + port + voltage 20624720 + port + voltage	£330.77

OPTIONS

Connector PG9 – DIN 43650 A IP65 Coil NPT thread PTFE seal Explosion proof enclosure: Protection II G/D EExdIICT6 ATEX	Included Included +£23.68 +£22.55 +£199.33
--	--

ELECTRICAL DATA

Voltage (-10% + 15%) Continuous duty 100%	Coil Size	Power		Insulation class	Enclosure	Electrical connections
		Inrush	Holding			
~ 24 - 48 - 110 - 230 (50 or 60 Hz)	40	48 VA	24 VA	F 155°C	IP 65 with connector	3 spades DIN 43650 DIN 40050 VDE 0110
= 12 - 24 - 48 (DC)		14 – 20 Watts				

CONSTRUCTION

Body: Brass
 Tube and internal parts: Stainless steel
 Seals and gaskets: NBR (Optional EPDM or FKM)
 Moulded coil: Resin

REPAIR KIT

Coil	40 + voltage
Complete plunger + O' rings + piston	KIT + valve part number

OVERALL DIMENSIONS

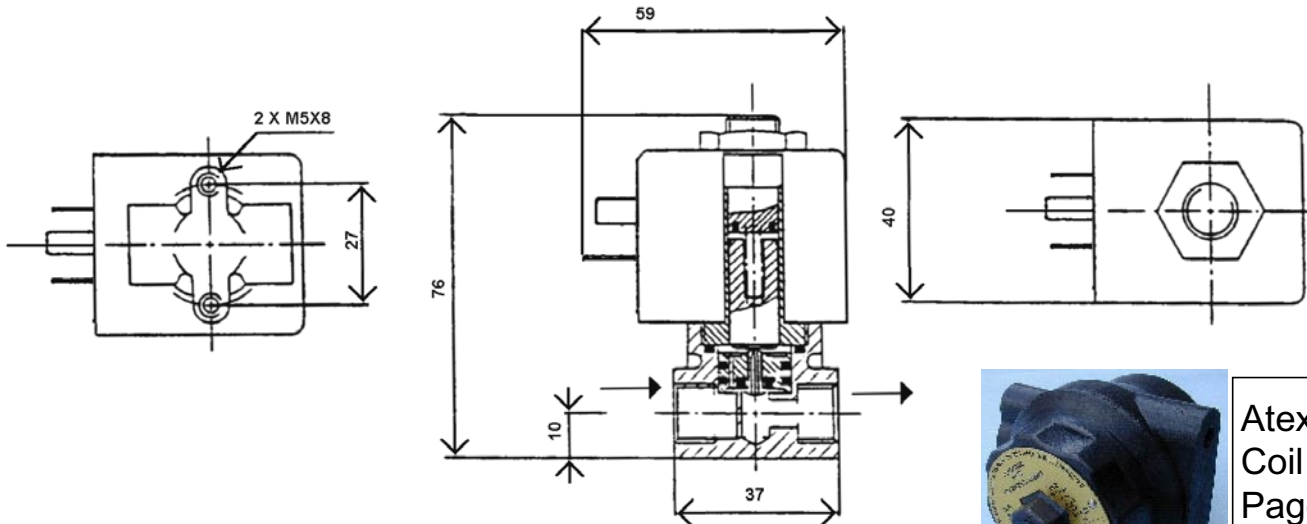

Atex
Coil
Page
144