

**GENERAL CHARACTERISTICS**

Mechanical Flow Switch for liquids or gaseous media, with contactless triggering of an adjustable reed switch. Rugged design in brass / bronze combination.

Female thread G1/4 to G3 bronze

- \* control and indication
- \* good repeatability
- \* dirt-resistant
- \* also for dark and/or contaminated liquids
- \* no pressurized or wetted glass parts
- \* exact setting of switch via scale



VDO-015GR010

**TECHNICAL DATA**

	G	Type	PN bar	Qmax. recom. l/min H <sub>2</sub> O		adjustable range l/min H <sub>2</sub> O		H mm	L mm	AF mm	X mm	weight kg
						standard	programme option					
bronze/brass	G 1/4	VDO-008GR010	100	15		2 - 10		183	68	29	12	1.3
	G 3/8	VDO-010GR010	100	15		2 - 10		183	68	29	12	1.3
	G 1/2	VDO-015GR...	100	20	30	2 - 10	4 - 20	183	68	29	13	1.4
	G 3/4	VDO-020GR...	25	40	60	4 - 20	10 - 40	184	73	32	11	1.5
	G 1	VDO-025GR...	25	60	85	10 - 40	20 - 60	188	87	41	12	1.7
	G 1 1/4	VDO-032GR...	16	100	145	20 - 60	30 - 100	190	98	52	13	2.2
	G 1 1/2	VDO-040GR...	16	150	220	30 - 100	50 - 150	195	113	59	14	2.9
	G 2	VDO-050GR...	16	250	290	30 - 100	100 - 200	203	137	72	17	4.2
	G 2 1/2	VDO-065GR...	16	400	475	100 - 200	180 - 330	224	160	85	26	5.8
	G 3	VDO-080GR...	16	600	720	180 - 330	400 - 600	224	148	100	23	7.8

Adjustable range is indicated for horizontally decreasing flow.

tolerance	±5% of full scale
media temperature	max. 120°C
average pressure loss	0.5 bar at Qmax.
hysteresis	depending on switch value minimum 0.5 l/min.

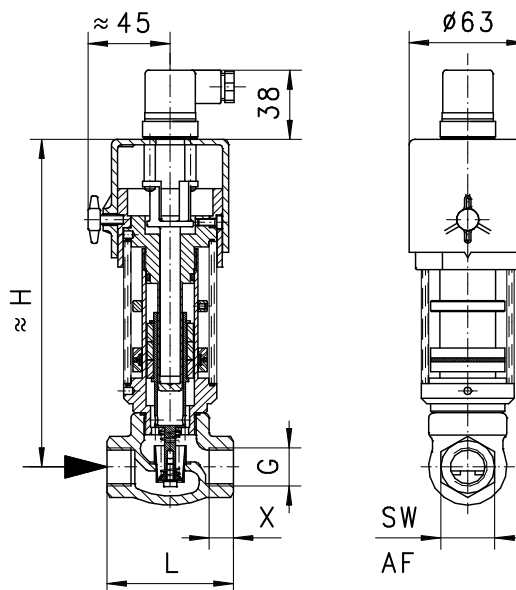

scale increments

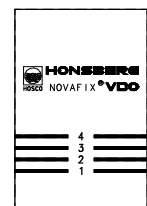

**MATERIALS**

housing	bronze Rg5/Rg6 nickel plated
piston	Ms58
spring	stainless steel 1.4310
piston guide	brass Ms58
seal	NBR
magnet	bariumferrite
cap	ABS
tube	acrylic (XT)

**ELECTRICAL DATA**

reed switch - wiring 0.213 change over  
250 V AC 1.5 A 50 VA  
plug DIN 43650-A  
protection class IP 44

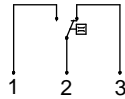

**MOUNTING POSITION**

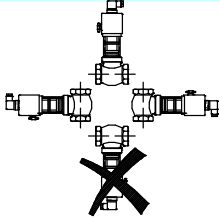

Installation position may influence switch value.

**METERING SUBSTANCES**

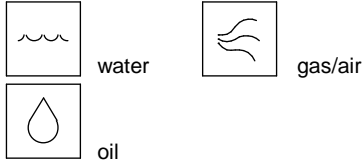

**NOMENCLATURE**

For combination see table "technical data"

VDO-	008	G	R	010	basic type specification	
	008				nominal diameter	DN 8 - G1/4
	010					DN 10 - G3/8
	015					DN 15 - G1/2
	020					DN 20 - G3/4
	025					DN 25 - G1
	032					DN 32 - G1 1/4
	040					DN 40 - G1 1/2
	050					DN 50 - G2
	065					DN 65 - G2 1/2
	080					DN 80 - G3
		G				female thread
			R			bronze
				010	adjustable range H <sub>2</sub> O horizontal	2 - 10 l/min
				020		4 - 20 l/min
				040		10 - 40 l/min
				060		20 - 60 l/min
				100		30 - 100 l/min
				150		50 - 150 l/min
				200		100 - 200 l/min
				330		180 - 330 l/min
				600	400 - 600 l/min	
Programme option BASIC					<input type="radio"/>	signal lamp temperature indicator 0-120°C protection class IP 65 material certification flange version in cast iron/bronze/cast steel or stainless steel
Special option VARIO					<input type="checkbox"/>	setting / adjustable ranges for oil or gas selected hysteresis rhodium contact temperature control 30-95°C wetted parts in brass or stainless steel temperature up to +150°C damping for gas control

**IMPORTANT FOR YOUR ORDER**

- Please indicate flow direction, metering substance and adjustable range with your order.
- With viscous liquids please indicate viscosity, temperature and metering substance (adjustable range on request)
- With gaseous media indicate pressure (relative or absolute), temperature and metering substance (adjustable range on request)

All technical changes reserved

●BASIC Standard ○BASIC Programme option □VARIO Special option ⊕ PLUS Accessories ✗ not recommendable