

GENERAL CHARACTERISTICS

The sensor consists of a rotor vane that is rotated by the speed of the flowing medium. The speed of rotation is proportional to the volume flow per unit time. The rotation of the rotor is detected by a Hall-sensor.

- * metal housing, with Hall-Sensor
- * large wear liberty by high-quality ceramic axle and ceramic bearings
- * output circuit PNP, NPN or Namur
- * no straight line in-out necessary
- * easy measurement of flow rates
- * inherently safe properties
- * modular construction with the most versatile connection systems
- * connections can be plugged and rotated

Female- / male thread G3/8 / G1 brass / stainless steel



RRH-025GMM

RRH-010GMM

TECHNICAL DATA

	G	Type	PN bar	Qmax. recom. l/min H ₂ O	metering range l/min H ₂ O			pulse/ litre (6)	frequency Hz of full scale (10)	weight kg
					(1)	(2)	(3)			
DN10	G3/8	RRH-010...020	100	1.8	0.1- 1.5	0.5- 1.5	0.1-0.5	4955	124	0.60
		RRH-010...050	100	12	0.2-10	2.0-10	0.2-2	1632	272	0.60
		RRH-010...070	100	16.8	0.4-12	2.0-12	0.4-2	860	172	0.60
DN25	G1	RRH-025...080	100	36	2- 30	3- 30	2- 3	544	272	1.90
		RRH-025...120	100	72	3- 60	5- 60	3- 5	295	295	1.90
		RRH-025...160	100	120	4-100	6-100	4- 6	126	210	1.90

The measurements were taken from left to right with the sensor stationary using water at 25°C.

- (1) **measuring range total**
- (2) **measuring range specified**
- (3) **measuring range non linear**
- (4) **extended operating range**
increase abrasion, $\Delta p > 0.5$ bar
- (5) **pulse/litre** (specification on the identification plate on each sensor)
- (6) **average pulse/litre**
- (7) **tolerance $\pm 3\%$** of the measured value
- (8) **variation $\pm 10\%$** of pulse/litre data (5) in the charge
- (9) **reproducibility ($\pm 1\%$ of full scale)**
is the repetitive accuracy of frequency related to l/min
- (10) **frequency max.** related to the applicable measuring range up to approx 0.5 bar pressure loss over the Sensor

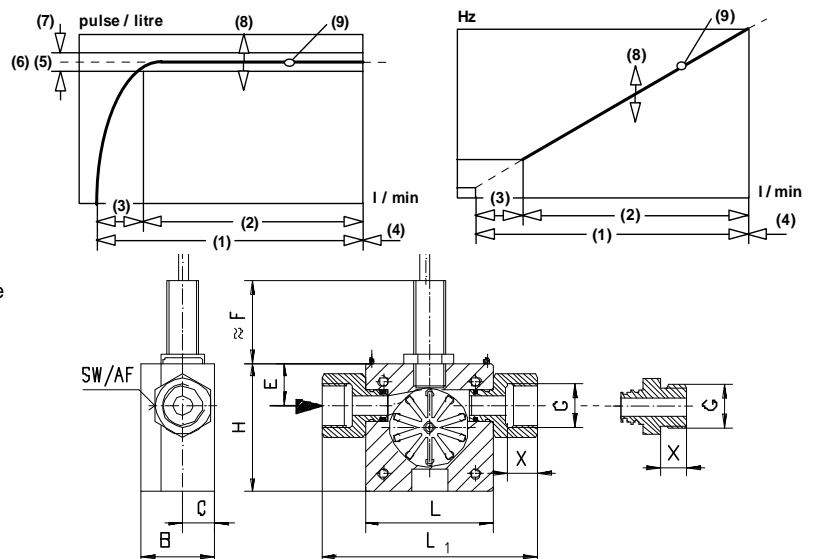

media temperature max. 100 °C

MATERIALS

housing	Ms58 nickel plat. or 1.4305
rotor	PVDF with magnet
bearings	Iglidur X
axle	ceramic ZrO ₂ -TZP
seal	viton
no medium contact	PVC cable 1.4305, 1.4301

DN	G	Type	H mm	L mm	L1 mm	B mm	C mm	E mm	F* mm	SW mm	X mm
10	G3/8	RRH-010G	50	50	84	29	12,5	16,5	38	22	12
		RRH-010A	50	50	84	29	12,5	16,5	38	22	14
25	G1	RRH-025G	70	70	110	53	23	27,5	33	38	18
		RRH-025A	70	70	122	53	23	27,5	33	38	18

* dimension F at Namur 8 mm cancel!

material options see nomenclature

ELECTRICAL DATA

quiescent current consumption	30mA
max. output current	100mA
sensor connection	2m cable or conection at locking plugs M12x1, 4-pole
short-circuit proof	ja
reverse polarity proof	ja
protection class	IP67

MOUNTING POSITION

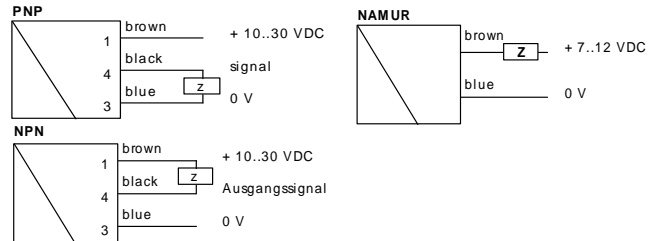
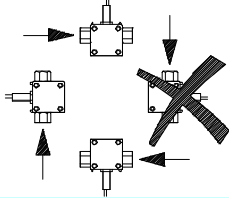

METERING SUBSTANCES

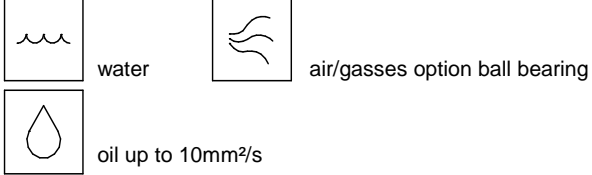

NOMENCLATURE

For combinations see table "technical data"

RRH-	010	G	M	M	020	V	05	V	P	K	basic type specification
	010										● DN 010
	025										● DN 025
		G									● female thread
		A									○ male thread
			M								● connection material brass Ms58 nickel plated
			K								● connection material stainless steel 1.4305
				M							● housing material brass Ms58 nickel plated
				K							● housing material stainless steel 1.4305
					020						● flow diameter Ø 2
					050						● flow diameter Ø 5
					070						● flow diameter Ø 7
					080						● flow diameter Ø 8
					120						● flow diameter Ø12
					160						● flow diameter Ø16
						V					● seal viton
						E					○ seal EPDM
						N					○ seal NBR
						K					□ seal Kemraz
							05				● rotor with 5 magnet
							02				○ rotor with 2 magnet
								V			● rotor material PVDF
									P		● PNP output
									N		● NPN output
									A		○ Namur output
									E		● ouput at suburb electronics (e.g. omni-RR)
										K	● 2 m cable
										S	○ connection at locking plugs M12x1, 4-pole

special applications: Switching output, frequency converter, current output and omni/flex processor

COMBINATIONS

omni-RR

local electronic unit,
2xNPN and PNP switch
4(0)..20mA output
graphical LCD display
with flashing LED
program ring



further transformers

- Flex switching and frequency exit, 0..10V or 4..20mA, pnp, npn
- ESA1 electronic monitoring unit
- ESK2 2 switchpoints - supply 24 V DC
- ESK3 1 switchpoint - supply 230 V AC
conceived for safety-relevant applications
- EFFS switch output
- EFFI current output 4(0)..20mA
- EFFF frequency output



All technical changes reserved

●BASIC Standard ○BASIC Programme option □VARIO Special option ⊕ PLUS Accessories ✗ not recommendable