

GENERAL CHARACTERISTICS

The instruments are used for liquids while a rotor in full-plastic housing generates flow-dependent revolutions which are detected optically.

- * compact dimension
- * control of small flow rates
- * max. viscosity 10mm²/s
- * magnet isolated

Nozzle Ø6/ Male thread G1/4A POM



RH-006TP100

TECHNICAL DATA

	G	Type	PN	Qmax. recom. l/h H ₂ O	metering range l/h H ₂ O	pulse/ litre	frequency Hz of full scale	weight g
POM	Nozzle Ø6	RH-006TP100	5	100	1.5 - 100	8400	233	50
POM	G 1/4A	RH-008AP100	10	100	1.5 - 100	8400	233	50
		RH-008AP250		250	6.0 - 250	3400	236	50

tolerance ±2%
 repeatability <0.8%
 media temperature -10..+80 °C

LINEARITY

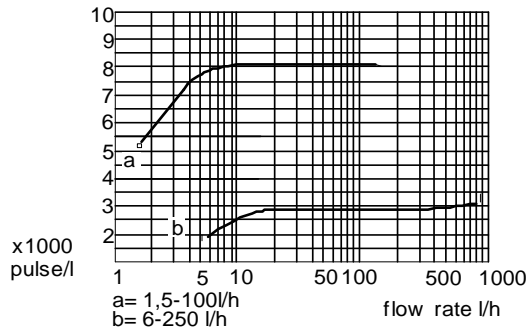

PRESSURE LOSS

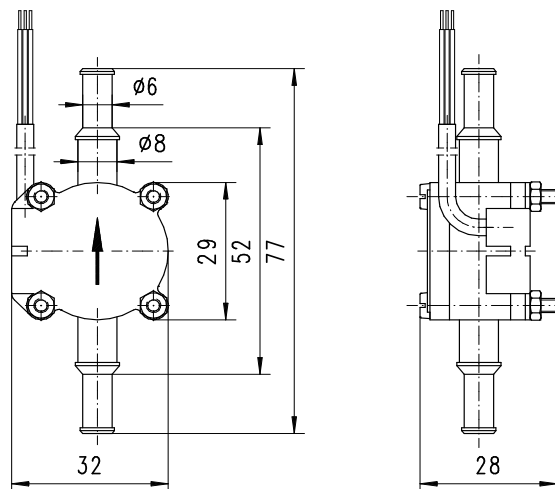
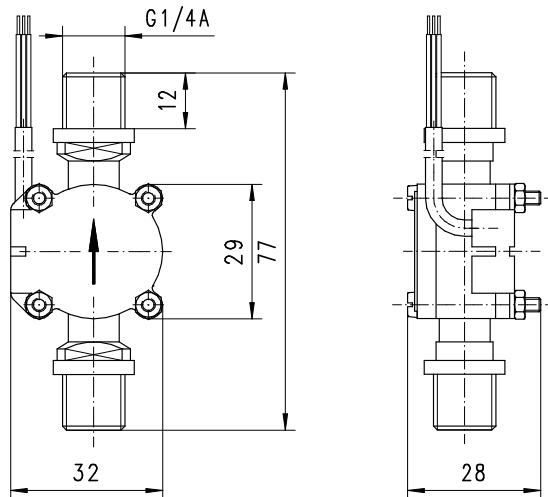
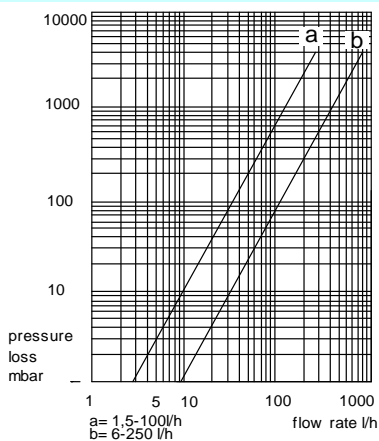

MATERIALS

- body POM
- rotor POM
- bearings POM
- axle nivapoint
- magnet hardferrite
- seal viton

ELECTRICAL DATA

hall sensor, contactless
supply: 4,5..24 VDC / I - out 15 mA of 24 V output
exit signal: precise rectangle
cable 3x0,14° Liyy - 1m

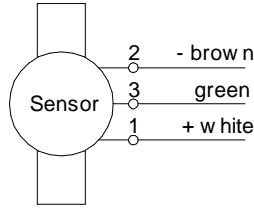

MOUNTING POSITION

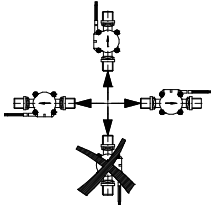

METERING SUBSTANCES

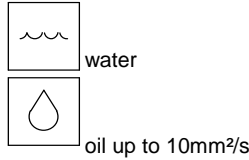

NOMENCLATURE

For combinations see table "technical data"

RH-	006	T	P	100	basic type specification
	006				● DN 6 - nozzle Ø6
	008				● DN 8 - G1/4A
		T			● nozzle
		A			● male thread
			P		● POM
				100	● metering range 1.5 - 100
				250	● metering range 6.0 - 250
Programme option					○ seal NBR, EPDM
BASIC					
Special option					□ seal Kalrez
VARIO					

All technical changes reserved

●BASIC Standard ○BASIC Programme option □VARIO Special option ⊕ PLUS Accessories ✗not recommendable