

GENERAL CHARACTERISTICS

The instruments are used for liquids while a rotor in full-plastic housing generates flow-dependent revolutions which are detected optically.

- * compact dimension
- * programmable limits
- * control of small flow rates
- * max. viscosity 10mm²/s
- * magnet isolated
- * signal output 4..20 mA

Male thread G1/4A POM / ECTFE (halar)



RA-008AP100

TECHNICAL DATA

	G	Type	PN	Qmax. recom. l/h H ₂ O	metering range l/h H ₂ O	pulse/ litre	frequency Hz of full scale	weight g
POM	G 1/4A	RA-008AP100	10	100	1.5 - 100	8400	233	100
ECTFE (Halar)	G 1/4A	RA-008AH100	10	100	1.5 - 100	8400	233	100

tolerance ±2%
 repeatability <0.8%
 media temperature -10.. +55 °C

PRESSURE LOSS

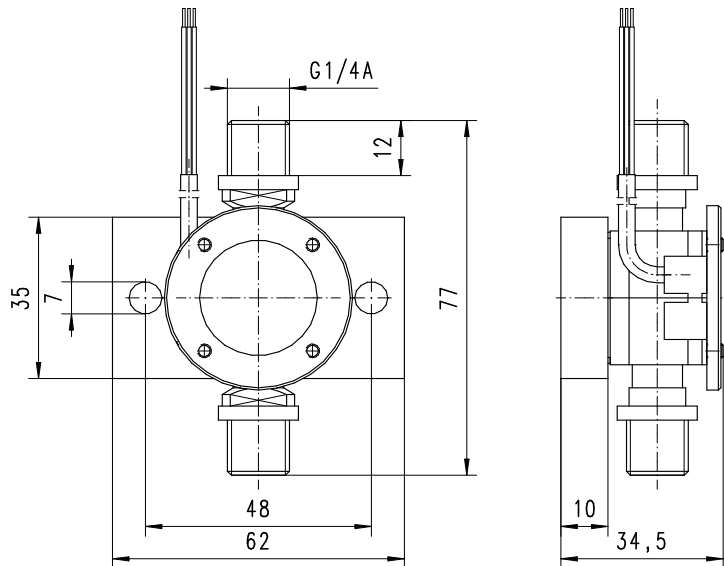
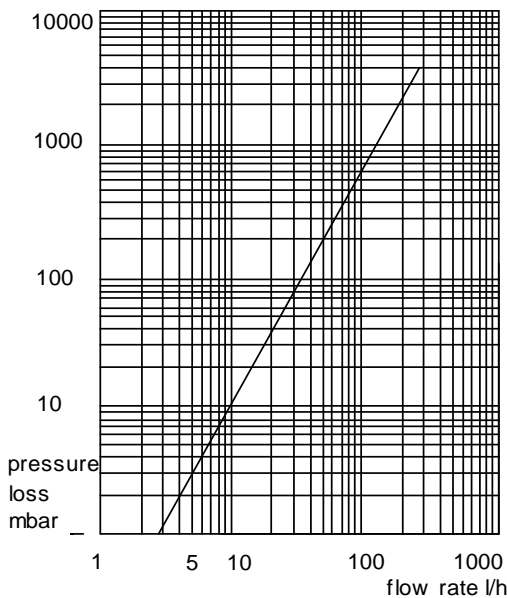

MATERIALS

	RA-...AP	RA-...AH
body	POM	ECTFE (halar)
rotor	POM	ECTFE (halar)
bearings	POM	rubin
axle	nivapoint	saphir
magnet	hardferrite	cobald-somarium
seal	viton	viton

ELECTRICAL DATA

inductive
supply: 24 VDC
exit signal: 4..20mA
cable 3x0,14°Liyy - 1m
cable allocation arbitrary

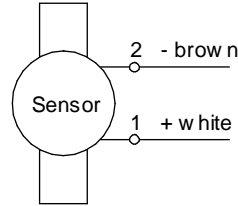

MOUNTING POSITION

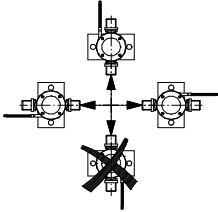

METERING SUBSTANCES

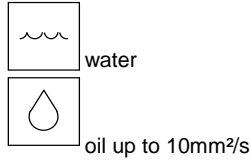

NOMENCLATURE

For combinations see table "technical data"

RA-	008	A	P	100	basic type specification
	008				● DN 8 - G1/4A
		A			● male thread
			P		● POM
			H		● halar
				100	● metering range 1.5 - 100
Programme option					○ seal NBR, EPDM
BASIC					
Special option					□ seal Kalrez
VARIO					

PROGRAMMING

The integrated micro controller computes each flow between the two measuring limit values 4mA and 20mA. For this, each measuring limit value must assigned (programmed) a flow. The following operational sequence describes this procedure:

- 1.) Adjust the desired flow for the 4mA measuring border.
- 2.) Operate briefly the reed switch (hold briefly the magnet pin to the reed switch).
(red LED shines and orange LED is out)
- 3.) after an firmly adjusted time the red LED shines and the orange LED flashes with about 4Hz. Now adjust the desired flow for the 20mA measuring border.
- 4.) Operate briefly the reed switch again (hold briefly the magnet pin to the reed switch).
(red LED shines and orange LED is out)
- 5.) after an firmly adjusted time the red and orange LED do not shine any longer. The micro controller check and save the adjusted worth. Afterwards the program starts with the "new" worth.

INDICATE

The yellow LED is shining in the operation. The brightness is dependent on the output current.
If the both measuring limit values are zero, then the two LED's (red and orange) flash with about 4Hz.
If the flow is lower as the calibrated flow for the 4mA-border, then the orange LED flash with about 8Hz and the red LED is out.
During the normal enterprise (flow between the two limit values) shines the orange LED and the red LED is out.
If the flow is higher as the calibrated flow for the 20mA-border, then the orange LED flash with about 4Hz and the red LED is out.
The red LED shines only during the Programming modus (see also Programming of the two measuring borders).

All technical changes reserved

●BASIC Standard ○BASIC Programme option □VARIO Special option ⊕ PLUS Accessories ✗ not recommendable