

**GENERAL CHARACTERISTICS**

Mechanical Flow Indicator for liquids with twin rotors for quantitative flow indication. The rotor provides a directly flow-proportional indication of the actual flow rate.

\* optional installation

Female thread G3/8 to G1 POM



PO-010GVA

**TECHNICAL DATA**

	G	Type	PN bar	Qmax. rec. l/min H <sub>2</sub> O	range l/min H <sub>2</sub> O	H mm	L mm	L1 mm	B mm	C mm	E mm	SW mm	X mm	weight kg
Questra	G 3/8	PO-010GVA020	16	1.5	0,1 - 1,5	50	50	84	29	12,5	16,5	22	12	0.1
	G 3/8	PO-010GVA050	16	10	0,2 - 10									
	G 3/8	PO-010GVA070	16	12	0,4 - 12									
	G 1	PO-025GVA080	16	30	2 - 30	70	70	110	53	23	27,5	38	18	0.4
	G 1	PO-025GVA120	16	60	3 - 60									
	G 1	PO-025GVA160	16	100	4 - 100									

media temperature max. 60°C

**MATERIALS**

body	Questra / PPS (Fortron 1140L4)
cover	PC transparent
rotor	PVDF
axle	ceramic
bearings	iglidur X
seal	viton

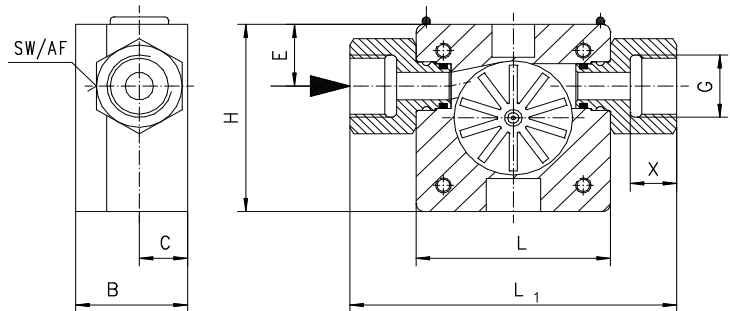

**MOUNTING POSITION**

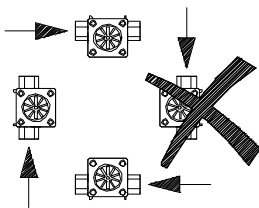

**NOMENCLATURE**

PO-	010	G	V	A	020	basic type specification
	010					● nominal diameter DN 10 - G3/8
	025					● nominal diameter DN 25 - G1
		G				● female thread
			V			● connection material PVDF
			M			○ connection material brass
				A		housing material
						● Questra / PPS with transparent cover PC
					020	● flow diameter Ø 2
					050	● flow diameter Ø 5
					070	● flow diameter Ø 7
					080	● flow diameter Ø 8
					120	● flow diameter Ø12
					160	● flow diameter Ø16

**METERING SUBSTANCES**

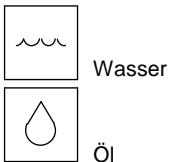

With higher viscosity instruments tend to higher starting values for rotor.

All technical changes reserved

●BASIC Standard ○BASIC Programme option □VARIO Special option ⊕ PLUS Accessories ✗ not recommendable