



- \* fast response time
- \* analogue output, switching outputs
- \* clear, easily readable, backlit LCD display
- \* changeable units in the display
- \* designed for industrial applications
- \* small and compact
- \* most simple installation

**PRINCIPLE**

The spring-supported piston is displaced by the flow. The flow-proportional position of the piston is transferred by a magnet to an analogue hall sensor element. The electronic circuitry converts the output signal of the hall sensor to a display reading completed by a dimension information. The electronic unit also provides two settable switches with adjustable hysteresis and a 4(0)..20mA output. Please take all additional data from the omni-sensor-family 51.1.omni and data sheet 51.1.omni2.

**TECHNICAL DATA**

measurement range	in different types 0.4..60 l/min (please see data sheet 1.1.HD1K and 1.1.MR1K.)
accuracy	1%
reproducibility	±3% EW
operating pressure	200 bar
operating temperature	0..70°C (with goose-neck max.120°C)
storage temperature	-20..80°C
supply voltage	18..30 VDC
power consumption	<1 W
output	4(0)..20mA, 2(0)..10V across 500 Ohm resistor to 0V.
switching values S1 and S2	PNP or NPN selectable, 300mA load in sum max., programmable as min. or max. value, short-circuit proof, reverse-polarity proof

hysteresis	adjustable, position of hysteresis depends on min or max.
display	graphical LCD display extended temperature range -20..70°C, 32x16 pixels, back-lit, shows value and units, LED signalling lamp with simultaneous message in display.
connection	at locking plug M 12x1, 5-pole
protection class	IP67
materials	housing stainless steel 1.4305
electronic housing	glass tempered mineral glass
	magnet cobalt samarium
	ring POM

Please take all additional data from 1.1.HD1K. Or 1.1.MR1K.

**TERMINAL ASSIGNMENT**

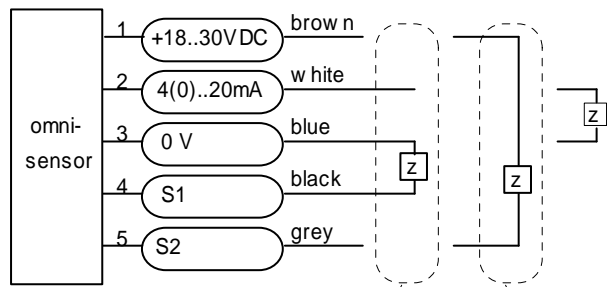

example: PNP or NPN

Z = load

The switchpoints are changing to PNP or NPN depending to your interface automatically (Push-Pull).

Signal output with 2(0)..10V  
Sample:

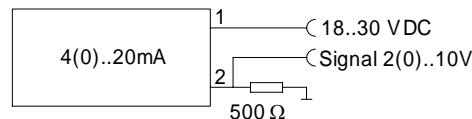

**MOUNTING**

The converters are connected by plugs to the flowmeter. There is no electrical connection between the local electronics and the flowmeter. Please note that the flowmeter and the smart electronics are paired to one another (same production number) and please follow the mounting instructions for the relevant primary sensor or Flowmeter.

**DIMENSIONS**

locking plug M12x1, 5-pole (accessory)

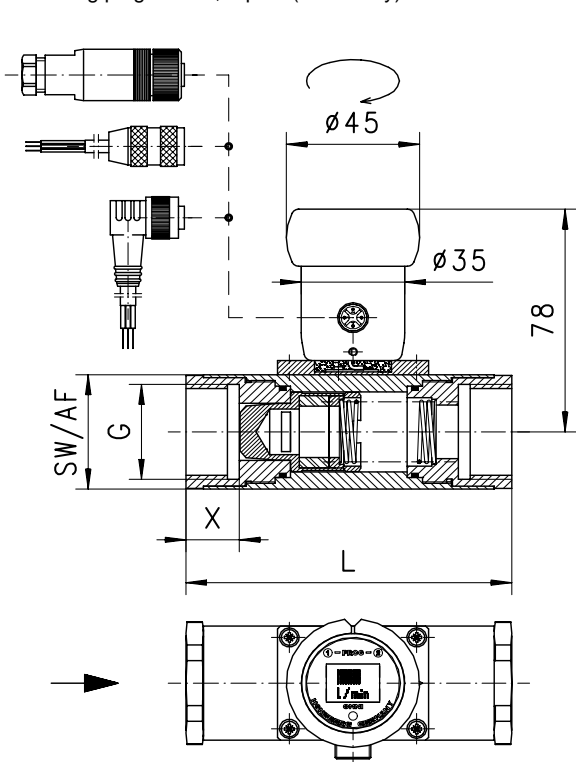

G = G1/4 , G3/8 , G1/2 , G3/4 , G1

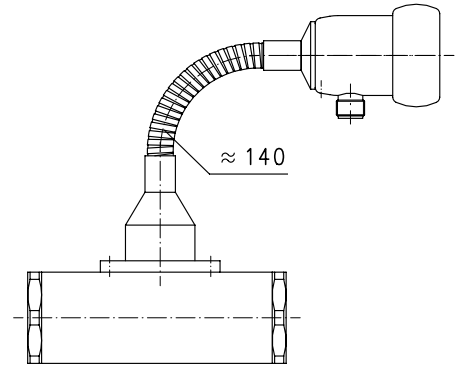

A **goose-neck** (optional) between the electronics head and the primary sensor provides complete freedom in the sensor alignment and reading direction. This option also gives thermal decoupling between both units.

Type	L
omni-MR1K	110
omni-HD1K	120

**NOMENCLATURE**

<b>omni-MR1K</b>	<b>S</b>	<b>basic type</b>
omni-MR1K		<b>specification</b>
omni-HD1K		● omni at flowmeter MR1K
	S	● omni at flowmeter HD1K
	H	● connection for locking plug M12x1, 5-pole
	O	○ goose-neck

**INFORMATION**

- please indicate flow direction
- the primary sensor is ordered as follows, e.g. MR1K-015GM025E with omni-MR1KS...

**ACCESSORY**

**Locking plug M12x1**

<b>K5</b>	<b>PU-</b>	<b>02</b>	<b>S</b>	<b>G</b>	<b>basic type</b>
K5					<b>specification</b>
KB05					● ready-made cable 5-pole
	PU-				● self makable cable 5-pole
					● material PUR
		02			● length 2 m
		05			● length 5 m
		10			● length 10 m
			S		● moulded-on plug
				G	● straight plug
				W	● angled plug 90°



All technical changes reserved

●BASIC Standard ○BASIC Programme option □VARIO Special option ⊕ PLUS Accessories ✗not recommendable