

DIFFERENTIAL PRESSURE LOW PRESSURE AND VACUUM

ANC4B 316 stainless steel or black anodised aluminium switchcase to IP66 standards.

Calibrated adjustment scale.

Settings from 0.25 mBar to 10.5 Bar.

Single or dual microswitch option.

ATEX Flameproof Version

CE Ⓜ II2GD EExd IIB + H₂T6 & T5

T6 Tamb -55 to +60°C

T6 Tamb -55 to +75°C

T5 Tamb -55 to +90°C

ATEX Intrinsically Safe Version

CE Ⓜ II1GD EEx ia IIC

T6 Tamb -50 to +78°C

T5 Tamb -50 to +93°C

T4 Tamb -50 to +128°C

DPF266 & DPF296 TITAN ATEX EExd, EExia CERTIFIED & INDUSTRIAL DIFFERENTIAL PRESSURE SWITCH

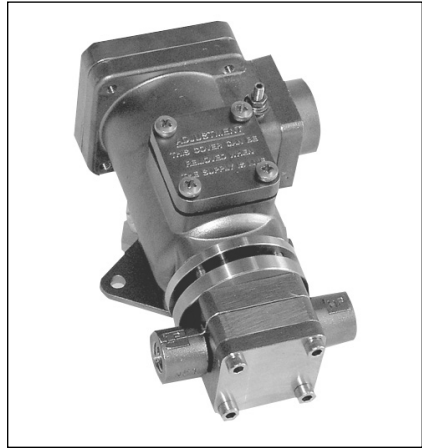

This range has been used to monitor filter blockage and air movement through ducting worldwide and has been specified extensively for offshore applications. Incorporating a diaphragm and two sealing Belloframs the switch offers reliable switching action when a differential pressure is required to be sensed. They can, by venting either the HP or LP connection, be used as a **low pressure** or **vacuum** switch. The DPF296 can be offered for high equalised static pressures up to 140 Bar, ranges are detailed below. Resistors can be incorporated for 'end of line' and short circuit monitoring. For specification and introduction to the Titan switch range refer to pages 46 & 47.

ADJUSTMENT RANGE (BAR D)	MAXIMUM WORKING PRESSURE EQUALISED (BAR D)	MAXIMUM WORKING PRESSURE ONE SIDED (BAR G)	DEADBAND FIXED (mBAR G)	SPRING CODE	DIAPHRAGM CODE
1.75 - 8.5	28	14	100 - 400	W	01
0.5 - 5.5	28	14	70 - 380	P	01
0.3 - 1.1	28	14	40 - 90	R	01
125 - 725mbar	10	7	10 - 75	G	02
50 - 250mBar	10	7	5.0 - 27.5	G	03
25 - 75mBar	10	7	4.2 - 7.5	T	03
15 - 55mBar	* 0.5	0.35	5.0 - 7.5	B	08
4 - 16mBar	* 0.5	0.35	0.75 - 2.0	R	08
1 - 5mBar	* 0.5	0.35	0.4 - 0.75	T	08
0.25 - 2.5mBar	* 0.5	0.35	0.05 - 0.25	T	12

* Max. equalised pressure on diaphragm code 08 can be specified up to 3.5 Bar and 1.75 Bar on code 12

ADJUSTMENT RANGES - DPF296

1.0 - 5.0	140	28	<900	G	F18
3.5 - 10.5	140	28	<1500	W	F27

DIMENSIONS IN MILLIMETRES

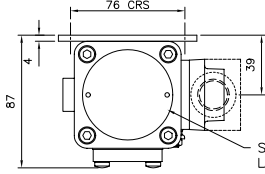

TYPICAL ARRANGEMENT DRAWING FOR REFERENCE ONLY

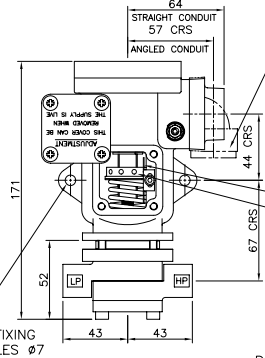
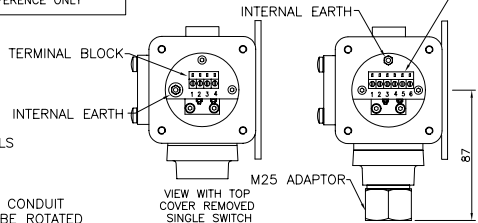

ALTERNATIVE CONDUIT ENTRY MAY BE ROTATED THROUGH 4 x 90° RIGHT OR LEFT HAND ENTRY AVAILABLE

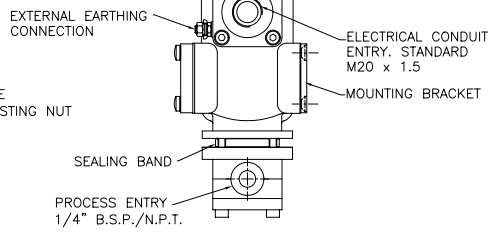

DPF266 1" DIFFERENTIAL PRESSURE SWITCH

INDUCTIVE RATING
5 AMP 250V AC
3 AMP 30V DC

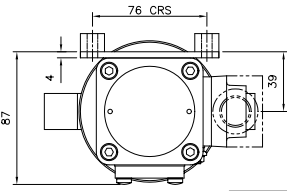

NOTE-DIMENSIONS AS 1" DP UNLESS SHOWN OTHERWISE

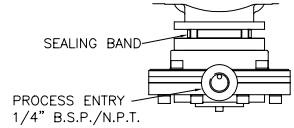
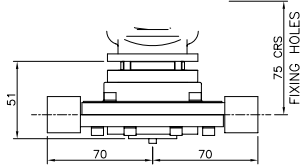
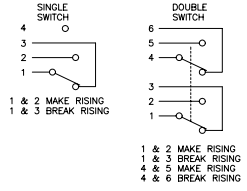

DPF266 2" & 3" DIFFERENTIAL PRESSURE SWITCH

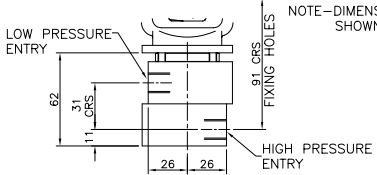

NOTE-DIMENSIONS AS 1" DP UNLESS SHOWN OTHERWISE

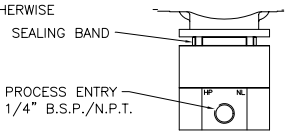

DPF296" DIFFERENTIAL PRESSURE SWITCH

TITAN DP

DIMENSIONS IN MILLIMETRES

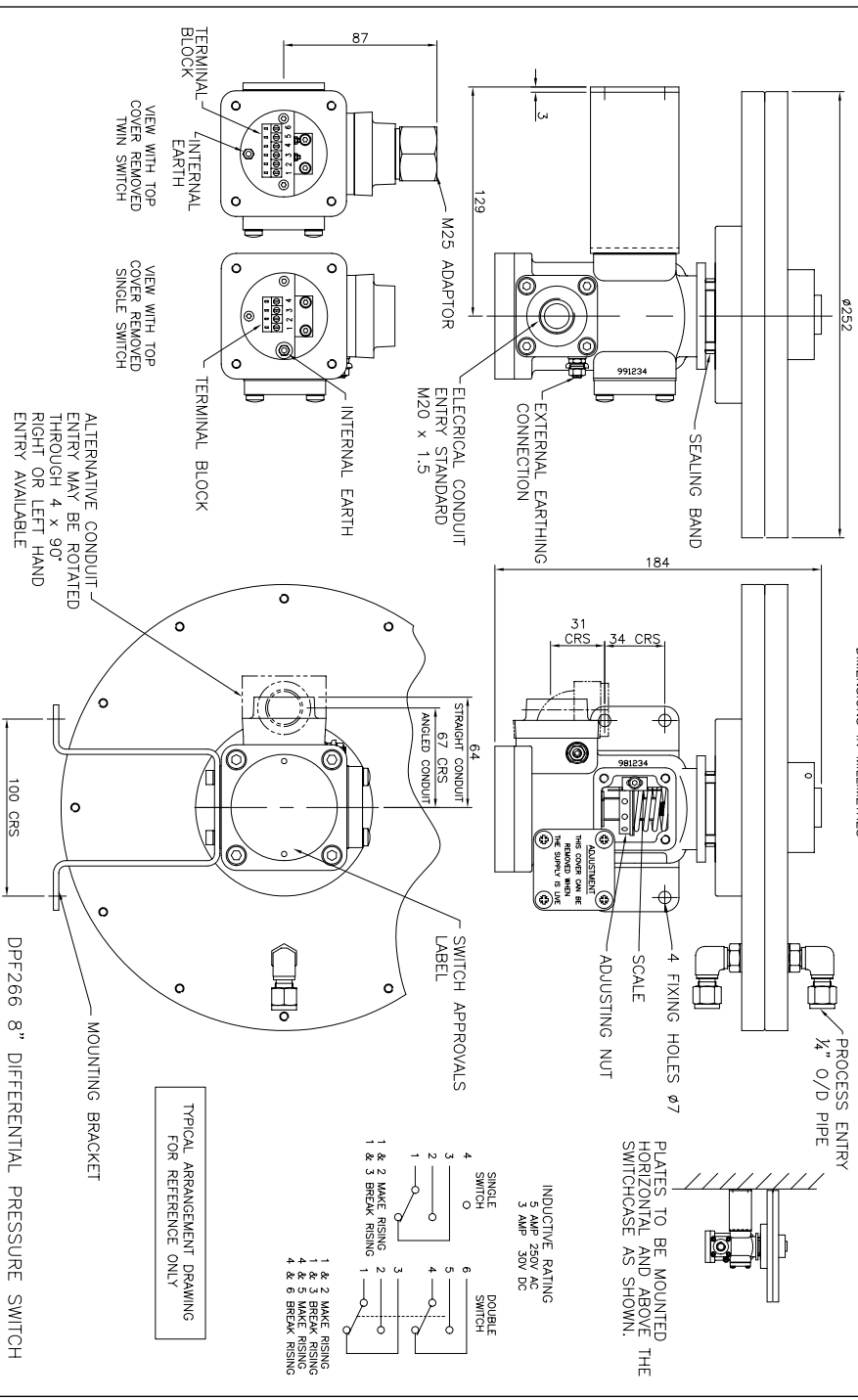

TITAN (XPB) ATEX EExd, EExia INDUSTRIAL SWITCHES

INTRODUCTION

The Titan **pressure, differential pressure, temperature, level and flow** switches are designed for use in environments where explosive gases and dust can be present (e.g. Gas fields, oil rigs and chemical plants etc.) and have been ATEX certified for CAT 1 EExia IIC T6, T5 & T4 and CAT 2 EExd IIB +H₂ T & T5.

Please note, our EExd switches are available with three maximum ambient temperature options, T6 + 60°C which is standard, T6 + 75°C & T5 + 90°C. Cable selected by customer upon installation should be suitable for ambient temperature, label for + 75°C states cable suitable for 85°C must be used and + 90°C states a 100°C requirement for cable.

These switches are manufactured from a high quality casting which offers robust construction and protection to IP66 for use within heavily polluted industrial and marine environments. A special feature of the instruments is the separation of the flameproof and adjustment compartments allowing for safe on-site adjustment of the set point with power on and the switch in operation.

The Titan range has been certified for mounting against a flush wall or bulkhead via the fitted bracket, therefore the flamepath minimum distances specified in BS EN60079-14:1997 are not applicable.

CALIBRATION

The design features a simple form of calibration adjustment against a scale plate. This allows users to either order units with a specific setting, or stock a mid range setting and then adjust to suit the application. This can be set safely with the switch supply live. On removal of the adjustment cover the adjusting mechanism can be turned with a small Tommy bar or Allen key. The setting is read from the centre of the red pointer ring against the calibrated scale plate. Rotation to the left will increase the set point and to the right decrease the set point. The adjustment mechanism incorporates a friction device to ensure set point will not change under vibration conditions.

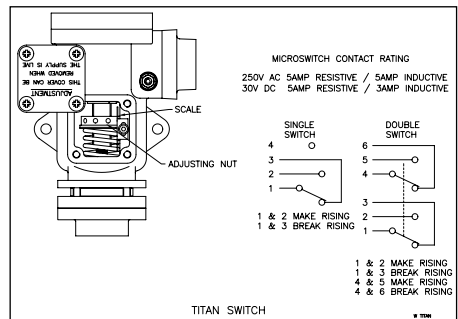

TECHNICAL SPECIFICATION

Switchcase and covers : ANC4B 316 stainless steel or black anodised aluminium switchcase.

Microswitch : 1 x SPCO/SPDT or 2 x SPCO/SPDT mechanically linked to provide DPDT switching action, reset of switches could be up to 3% apart, dual microswitches may increase deadband by a factor of two.

Contact material : Gold plated silver contacts.

Microswitch rating :

5 Amps @ 250 VAC resistive and inductive.

5 Amps @ 30VDC resistive, 3 Amps @ 30 VDC inductive.

Electrical connections : Terminals suitable for cable 0.5 - 2.5 mm².

Electrical Conduit Entry : M20 x 1.5 or 1/2" NPT.

Environmental Protection : Switches have been tested and certified by an external test house to IP66 in accordance with BS EN 60529 : 1992.

Vibration and shock parameters : Switches were subjected to Ministry of Defence Type Approval System Test Vibration DGS 350 Paras 0602 & 0603. Shock – BR3021.

Temperature Limitations : Pressure, Vacuum and Differential Pressure

Ambient : -50 to +85°C (standard) -50°C to 125°C (special)

Process : Diaphragm actuated -50 to +90°C (Nitrile) or -20 to +150°C (Viton).

Piston actuated -40 to 120°C (Nitrile) or -20 to +150°C (Viton).

Storage : -60 to +80°C

(for temperature, level and flow switches please refer to specific pages).

Certification : All switches are CE certified and marked in accordance with the following EU directives

Industrial : 73/23/EEC Low Voltage Directive

EEExia : 94/9/EC ATEX coded CE II 1GD EEExia IIC for CAT 1 (Zone 0) areas

EEExd : 94/9/EC ATEX coded CE II 2GD EEExd IIB + H₂ for CAT 2 (Zone 1) areas

Accuracy : +/-1% at 20°C, setting accuracy : 2%.



XPB XPB/R T6

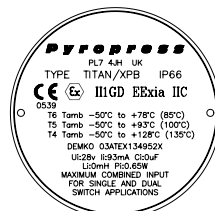

IS