

Pressure Snubbers

SM

FEATURES

- Type SM & SMA = Male/Female
- Type SMM = Male/Male
- Maximum pressure = 600 Bar

CAUSES OF SWITCH DAMAGE

1) Pressure peaks :

Increases in fluid volumes/pressure caused by pressure surges.

2) Pulsations :

Undetected resonant frequencies caused by "Fluid Borne Noise".

SYSTEM PROTECTION

When Pressure switches are used in hydraulic systems, they are subjected to pressure peaks and pulsations, which may be undetectable under usual testing methods. If precautionary measures are not built into the system, extensive damage may occur to the switches.

Pressure surges/pulsation risks can be minimised by protecting your system using one of our recommended snubbers. These snubbers are a low cost accessory to counter high pressure spikes or surges, which can save on long term costs due to unnecessary failure of your equipment.

SNUBBER GRADES			
10	15	20	25
FINE	<---->		COARSE

N.B.

SM..R14* is the Standard Model held in stock

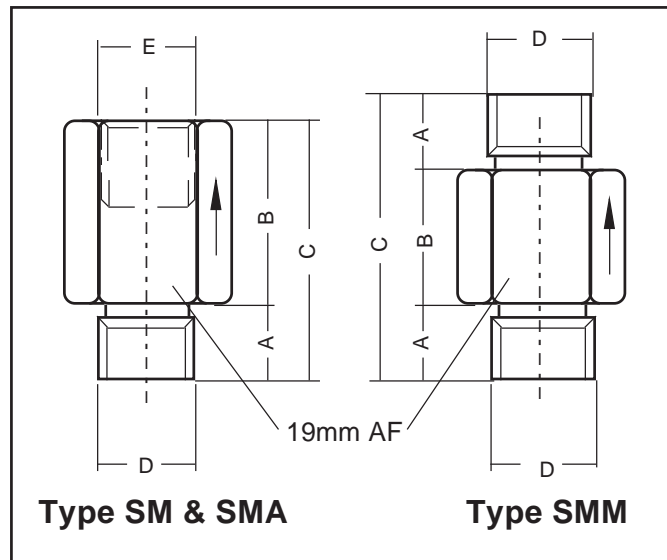

Type	A	B	C	D	E
Snubber SM (Male/Female thread)					
SM...R18	10	28	38	1/8" BSP	1/4" BSP
SM...R14*	12	26	38	1/4" BSP	1/4" BSP
SM...M10	10	28	38	M10x1.5	1/4" BSP
SM...M12	12	26	38	M12x1.5	1/4" BSP
Snubber SMM (Male/Male thread)					
SMM...R14	12	14	38	1/4" BSP	
Snubber SMA (Male/Female thread)					
SMA...R12	32	16	48	1/2" BSP	1/2" BSP

PRESSURE-VACUUM-LEVEL LTD

Unit 9, Lexden Lodge Industrial Estate, Jarvis Brook,
Crowborough, East Sussex, TN6 2NQ U.K.

Tel: +44(0)1892 66 44 99 Fax: +44(0)1892 66 36 90

Web: www.pvl.co.uk Email: info@pvl.co.uk

